

Diving 5

<i>EDIT JUDGE</i>	1	2	3	4	5	6	7	8	9	10	<i>POSITION</i>						
	G	W	E	R	T	Y	U	I	D	P					3 RANK-1	A	
<i>SCORES</i>	1	2	3	4	5	6	7	8	9	10	↑	PKF	B				
	A	S	D	F	G	H	J	K	L	I		↓	LOCK	C			
	1.5	2.5	3.5	4.5	5.5	6.5	7.5	8.5	9.5	0		• 2 POINT DEDUCT •	• FAILED DIVE •	• REFLASH •	.5 SPACE	• NEXT DIVE •	TIME
	Z	X	C	V	B	N	M	.	.	.							
	<i>DIVING</i>																

For the System 5 Sports Timer Software User Guide

F508 Rev. 0698



1551 East Eleventh Street
 Loveland, Colorado 80537-5056
 Phone: 970/667-1000
 Facsimile: 970/667-0988
 Toll Free U.S. and Canada 800/279-0111

TABLE OF CONTENTS

1 Introduction

Dear Customer	1-1
Diving 5 Contents	1-2
Scope of this User Guide	1-2
Contents	1-2

2 Setup/Tutorial

Setup	2-1
Installing Judging Terminals	2-1
Running Diving 5	2-2
Scoreboard Setup	2-4
Tutorial	2-6
Introduction	2-6
Running a Sample Meet	2-7

3 Reference

Self Test/Loading Diving 5	3-1
Summary	3-1
Operation	3-1
Display Screen	3-2
Summary	3-2
Operation	3-3
Keyboard	3-3
Summary	3-3
Alphabetic Keys	3-4
Edit Judge	3-4
Scores	3-4
2 Point Deduct	3-4
Failed Dive	3-4
Reflash	3-5
Space	3-5
Next Dive	3-5
Up And Down Arrow Keys	3-6
Position Keys	3-6
Numeric Keypad	3-6
Function	3-6
Operation	3-6
C/E (Clear Entry)	3-7
Enter	3-7
Console Keys	3-7
Enter	3-7
Quit	3-7
Battery Check	3-8
Help	3-8
Softkeys	3-8
Summary	3-8
Operation	3-8
Options Screen Softkeys	3-9
Judging Softkeys	3-14
Enter/Edit	3-15
Display	3-23
Print	3-25
Stored Data	3-27
Setups	3-30
Misc	3-37

INTRODUCTION

Dear Customer:

Colorado Time Systems would like to thank you for purchasing the Diving program for your System 5 Sports Timer. Diving 5 is a full-featured yet easy to use automatic diving meet program. Diving 5's large memory capacity allows you to store up to 600 divers and their scores and makes it easy to set up and run event the largest diving meets.

The Diving 5 program is an integrated part of your total System 5 Sports Timer package. This means that your experience with other programs for the System 5, including Swimming, Pace Clock, and many others, make it easier for you to use Diving 5. However, even if you are an experienced user of other System 5 programs, you should read this user guide to ensure that you take full advantage of the many advanced features Diving 5 offers.

Colorado Time Systems is committed to provide you with sports timing solutions for all your needs. The addition of Diving 5 to the growing family of System 5 programs is another example of our commitment to ensure that your System 5 remains the industry leader in state of the art technology, features, and ease of use.

If you should experience difficulties with any of your Colorado Time Systems' equipment, check the appropriate user guide for a solution first. If the user guide does not offer a solution to the problem, call Colorado Time Systems' Customer Service Department toll-free (US and Canada) at (800) 287-0653 or (970) 667-1000 (international).

Diving 5 Contents

Your basic Diving 5 package contains the following items:

- ✍ Diving 5 Keyboard Insert
- ✍ Diving 5 User Guide

Additional diving options, including judging terminals, can be ordered separately.

Scope of this User Guide

This user guide addresses all issues relating to the normal operation of the Diving 5 program on the System 5 Sports Timer. It is written with the beginning timer operator in mind, but also contains detailed information of interest to experienced operators. Use the Table of Contents and Index to locate specific information quickly.

For information on setup, care, and maintenance of your System 5 Sports Timer, refer to the *Swimming 5 User Guide*. It contains a great deal of general information with which every operator should be familiar.

Contents

Chapter 1 - Contains introductory and background information on the Diving 5 program.

Chapter 2 - Covers Diving 5 program and hardware setup and basic operating instructions, including tutorial instructions to help you begin using Diving 5 right away.

Chapter 3 - This is the Reference section which describes in detail the operation of all features included in the Diving 5 program. It includes descriptions of all keyboard and softkey functions and contains display screen examples for every major function. Use this chapter to learn how to use specific features or to refresh your memory on any aspect of Diving 5.

Index - A complete index provides quick access to specific information. The index is cross-referenced and organized to make finding information in this user guide fast and easy.

SETUP/TUTORIAL

The first part of this chapter describes how to set up your Diving 5 system. Setup is easy, but must be done correctly to ensure proper operation of your Diving 5 program and System 5 Sports Timer. The second part of this chapter gives you step-by-step instructions for programming and running a diving meet.

Setup

Installing Judging Terminals

X **Note:** Make sure your System 5 is turned **off** before connecting judging terminals. When using judging terminals, **you must use the approved external power supply with your System 5 Sports Timer. Your timer's internal battery power is not sufficient to power the judging terminals.**

Colorado Time Systems' remote judging terminals are a very useful addition to your Diving 5 package. Judging terminals allow the judges to enter their scores from the judging table, eliminating the inconvenience and effort involved in manually entering scores from the Diving 5 keyboard insert. Judging terminals are easy to install. Simply place up to ten judging terminals on the judging table, route the cables to the Judging Interface box and insert the cable connectors into the indicated jacks on the box. Route the cable from the interface box to the Judges I/O connector on the I/O Panel of your System 5 and attach the cable connector to it. Figure 2-A shows a wiring diagram.

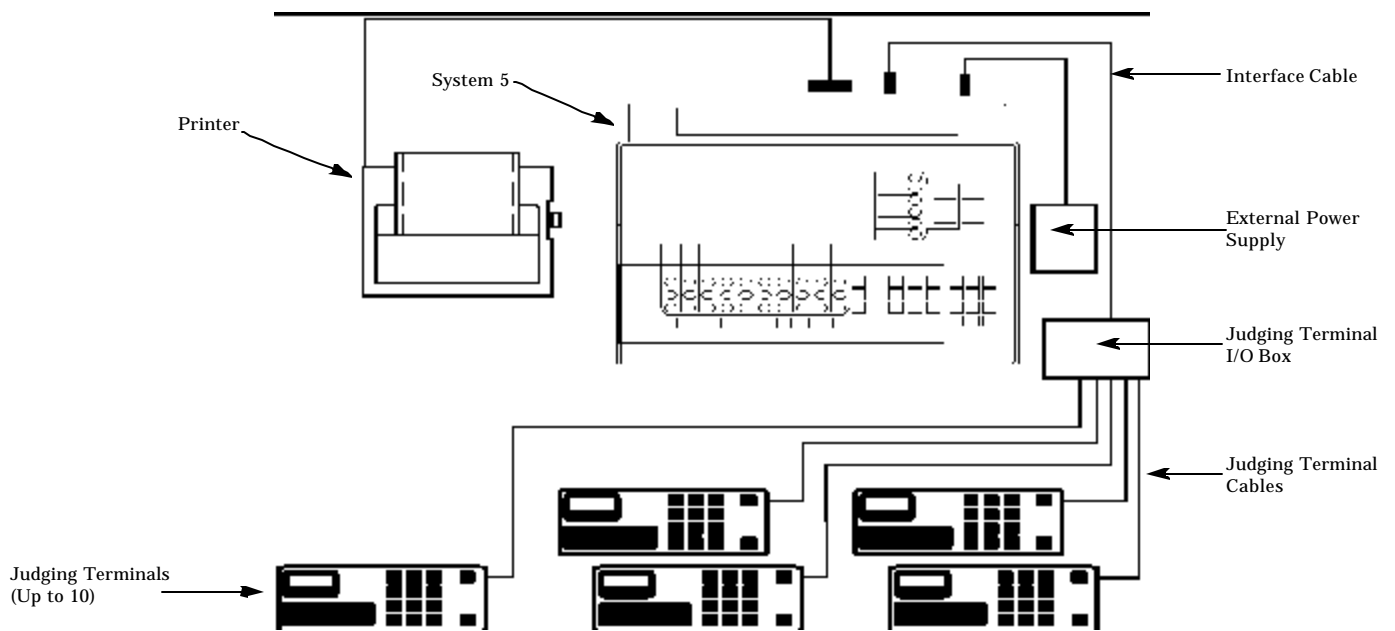

Figure 2-A Judging Terminal Wiring Diagram

When you run the Diving 5 program, select the desired number of judges option from the Options softkey menu. Refer to Figure 2-I for an example of these softkeys. The instructions below explain how to run Diving 5.

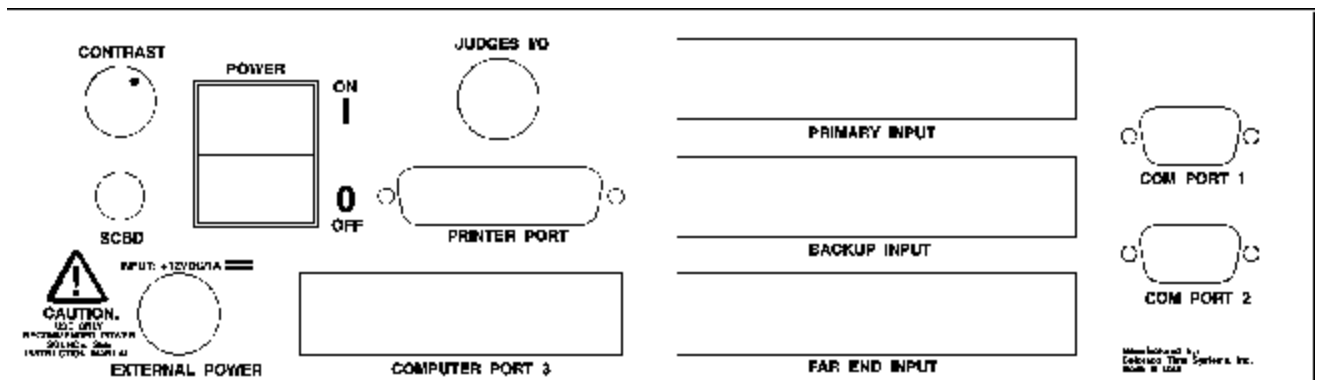

Figure 2-B System 5 I/O Panel

Running Diving 5

- 1) Make sure your scoreboard cable is properly connected. Diving 5 does not use touchpad or backup button inputs, but you may leave the touchpad and backup cables connected to your System 5 if you wish.
- 2) Attach the cable from your printer to the Printer Port on the I/O panel of your System 5. Tighten the screws on the cable connector.
- 3) Remove the Swimming keyboard insert from your System 5 by sliding it out of the keyboard pocket. Locate the Diving 5 keyboard insert and slide it into the keyboard pocket, making sure it is properly aligned.

- 4) Turn on your System 5. After the standard initial checks, the Sports menu appears.

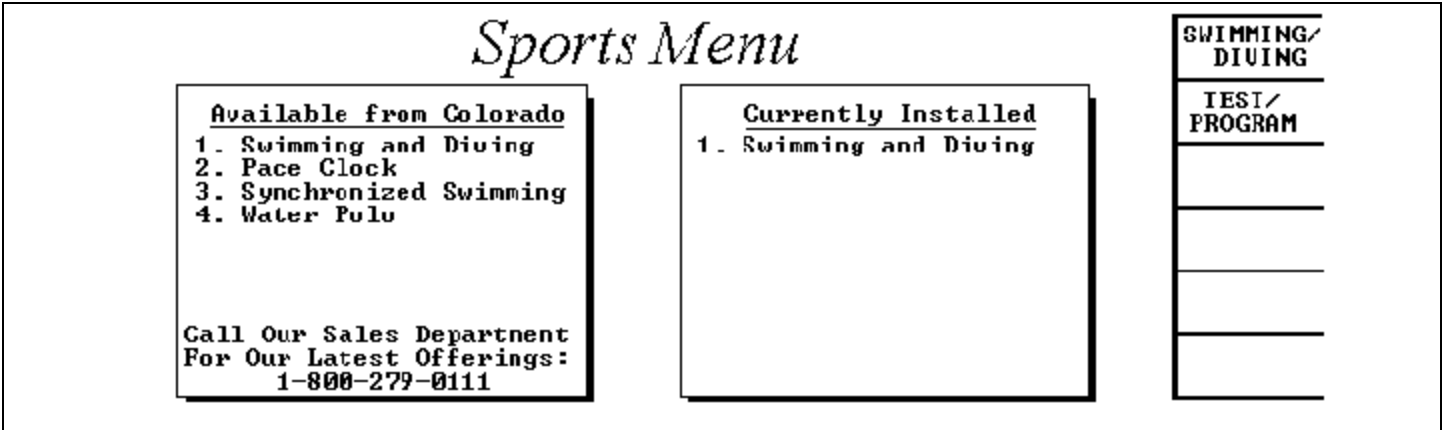

Figure 2-C Sports Menu

- 5) The Sports Menu displays the sports software available from Colorado Time Systems and the sports programs currently installed in you System 5. Press the **Swimming/Diving** softkey. Swimming 5 loads and the Swimming 5 Main softkey menu is displayed.

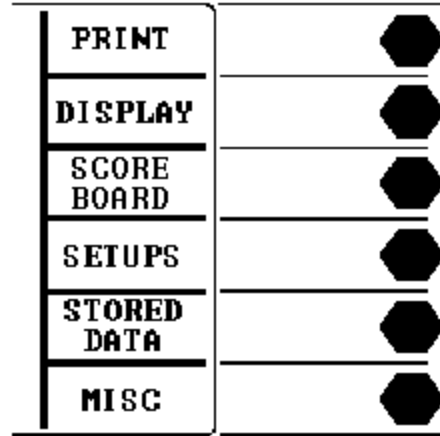

Figure 2-D Swimming Main Softkey Menu

- 6) To run Diving 5, press the **Misc** softkey to display the Swimming 5 Misc menu.

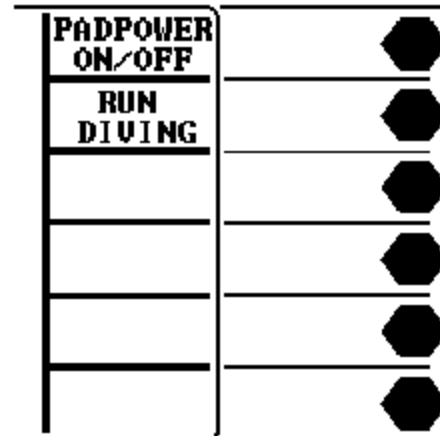

Figure 2-E Swimming Misc Softkey Menu

- 7) Next, press the **Run Diving** softkey and press the **Yes** softkey

in response to the confirmation prompt. In a few seconds, Diving 5 loads. For tutorial operating instructions refer to page 2-6. Refer to Chapter 3 for complete software operating instructions.

Scoreboard Setup

Introduction

An important part of your diving meet is the scoreboard display. Diving 5 uses many different scoreboard modules to display detailed information about a diving meet. Diving 5 lets you choose how many modules to use and how to use them. Scoreboard module configuration is a complex task not recommended for the novice System 5 operator. Before attempting to configure your scoreboard, carefully read the scoreboard configuration section in Chapter 3 of this user guide and in Chapter 2 of your *Swimming 5 User Guide*.

**Diving 5
Scoreboard
Modules**

Figure 2-F shows the diving scoreboard modules with signage installed and module numbers indicated.

JUDGE	SCORE	Module #	ROUND	AWARD
1	8.8d	01 11	88	888.88
2	8.8d	02	DD	AWARD
3	8.8d	03 12	8.8	88.88
4	8.8d	04	1 2 3 4	
5	8.8d	05 13	8.8 8.8 8.8 8.8	
6	8.8d	06	5 6 7 8	
7	8.8d	07 14	8.8 8.8 8.8 8.8	
8	8.8d	08	9 0 AWARD	
9	8.8d	09 15	8.8 8.8 88.88	
0	8.8d	0A		
DD	ROUND	AWARD		
8.8	8	88.88		
		0B	DIVER	CURRENT
		17	88	888.888
DIVER	CURRENT	TOTAL		
88		888.88		
		0C	DIVER	LEAD
		18	88	888.888
DIVER	LEAD	TOTAL		
88		888.88		
		0D	9 ROUND	AWARD
		18	88	888.888
DIVER	LEAD	TOTAL		
88		888.88		
		0D	9 ROUND	AWARD
			88	888.888

Figure 2-F Diving Scoreboard Modules and Signage

Single-Line Scoreboard Display

Diving 5 can display all meet information on a single-line scoreboard, module 0F, by sequencing through the scores and other information for each dive. Diving 5 is very similar to the Swimming program in this way. The following diagram shows how diving information is displayed on a single-line scoreboard.

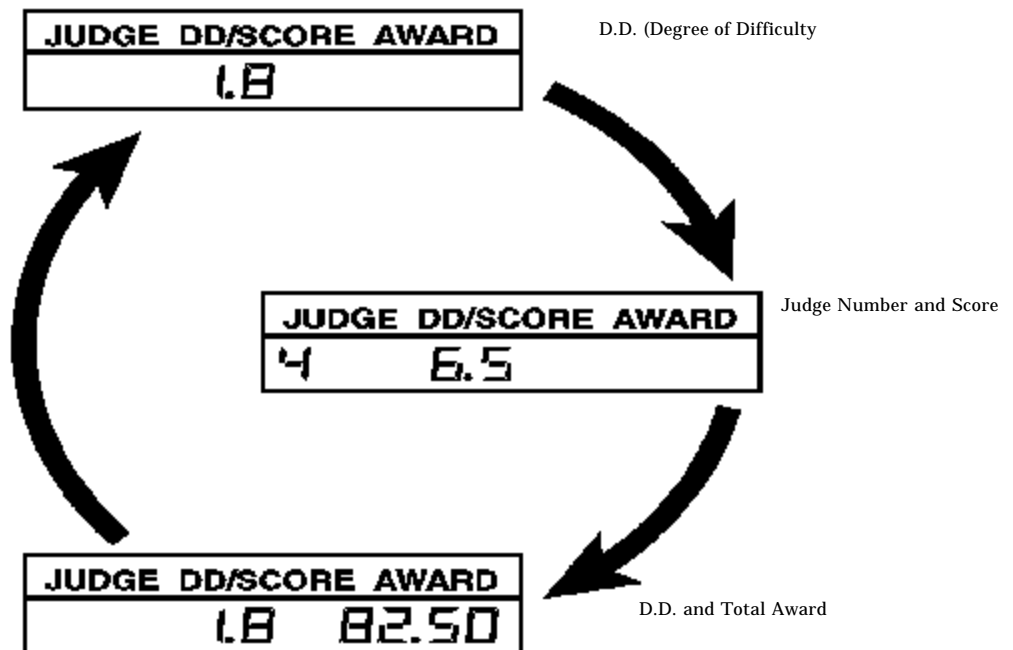

Figure 2-G Single-Line Scoreboard Display Sequence

Tutorial

Introduction

This section contains a brief tutorial which covers the basic elements needed to run a diving meet using Diving 5. This tutorial is not intended to cover every possible contingency in a meet. Rather, it gives the beginning operator a quick overview of the basic operation of Diving 5. Take a few minutes to follow this tutorial. If you are unsure about how to use a Diving 5 feature, refer to Chapter 3 in this user guide for a full explanation. **Refer to pages 3-3 to 3-8 for keyboard and console key examples.** Use the Index or Table of Contents to locate quickly the specific information you need on individual keys.

Modes of Operation

The Diving 5 program offers two ways to run a meet: Enter Data on the Fly and Program mode. Enter Data on the Fly mode is quick and simple, but requires more operator input before each dive. Program mode requires some time to set up before the meet, but requires almost no data from the operator during the meet.

Running The Sample Meet in Enter Data On The Fly Mode

This tutorial is written to show you how to run a meet in Program mode, but you may run it in Enter Data on the Fly mode by entering the data manually for each dive during the sample meet instead of programming Diving 5 in advance. Turn to page 2-12 for instructions on setting up and running a meet in Enter Data on the Fly mode.

Running A Sample Meet

Running Diving 5

Turn on your System 5. After the initial system checks, the Sports menu appears. Press the **Swimming/Diving** softkey. When the Swimming 5 Main softkey menu appears, press the **Misc** softkey and then in succession press the **Run Diving** and **Yes** softkeys. Refer to page 2-3 for screen examples. Diving 5 loads and is ready to use.

Programming The Meet

The first screen you encounter in Diving 5 offers you three softkey options for running a diving meet - the fourth option returns you to Swimming 5.

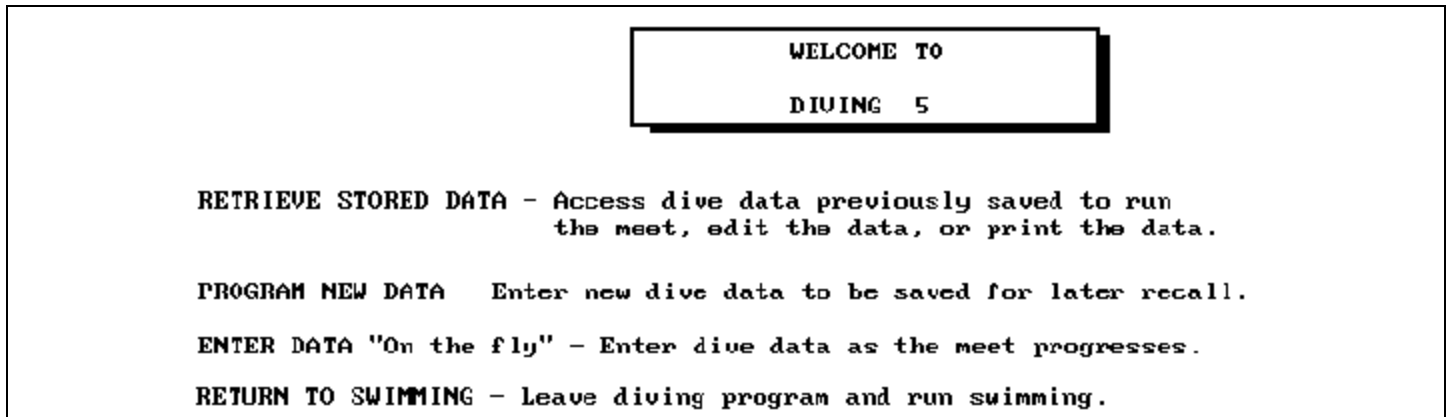

Figure 2-H Diving 5 Options Screen

You can either **Retrieve** meet data previously saved, **Program** new meet data, or **Enter data on the fly**. The first option does not apply to this tutorial, but is the one you would choose if you had already programmed all meet data in advance or wanted to edit or print data from a meet which had already taken place. The **Enter Data on the Fly** option is described on page 2-12.

RETRIEVE STORED DATA	⬢
PROGRAM NEW DATA	⬢
ENTER DATA ON THE FLY	⬢
RETURN TO SWIMMING	⬢
	⬢
	⬢

Figure 2-I Diving 5 Options Screen Softkey Menu

For this tutorial, press the **Program New Data** softkey. The next screen prompts you to select the event type. Use the arrow keys on the keyboard insert to highlight the desired event and press **enter**. For this tutorial, simply press **enter** to select the **1 Meter Springboard** event, which is already highlighted, as shown in

Figure 2-J.



Figure 2-J Select Event Type

The next screen, shown in Figure 2-K, prompts you to select the diver for which to enter dive information. Press **enter** to select Diver 01. The following screen (not shown) prompts you to type the name of Diver 01. Type **JOHN** using the alphabetic keys on the keyboard insert and press **enter**.

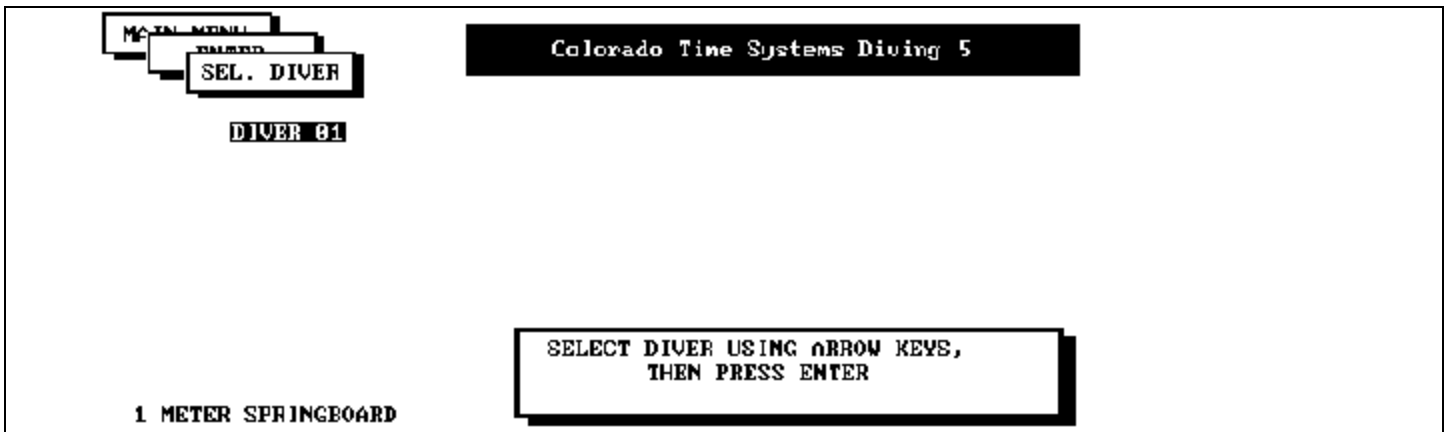

Figure 2-K Select Diver 01

The next screen prompts you to select the Round number. Select Round 01 using the arrow keys and press **enter**. The display then changes, as shown in Figure 2-L, to prompt you to enter the dive for Round 01. Using the numeric keypad and position keys, type **103C** in the Dive Number field and press **enter**.

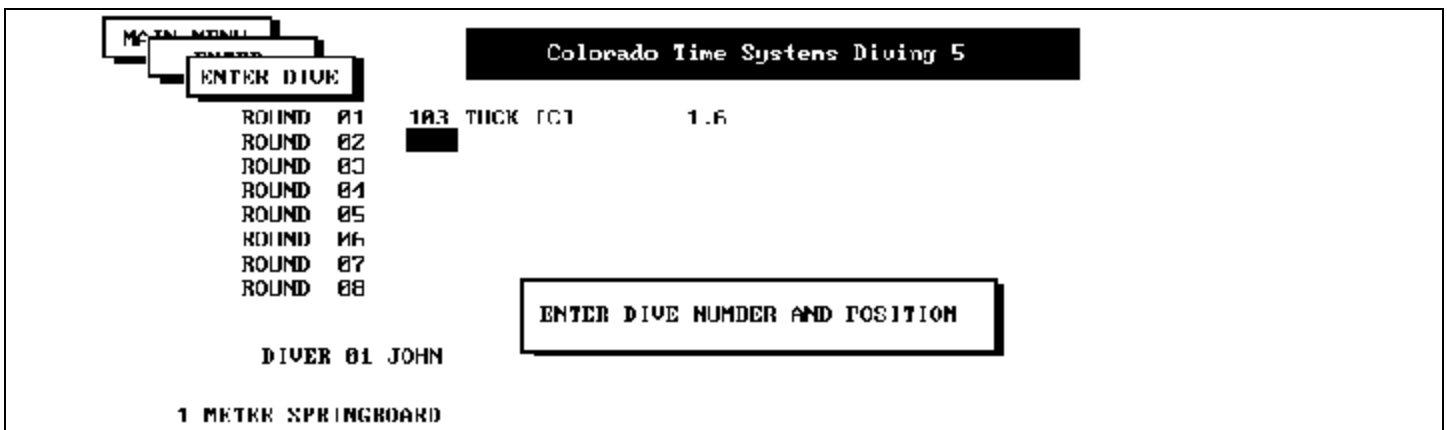

Figure 2-L Type the Dive Number and Position

Diving 5 automatically posts the D.D. (Degree of Difficulty) for the dive number entered and prompts you to select the next round for which to enter a dive. Round 02 is already highlighted, so simply press **enter** to select it. Type **104B** using the numeric keypad and position keys and press **enter**. Press **quit** to exit when finished entering dive information for the first diver.

X Note: When you type the dive number and position, Diving 5 prompts you to accept the D.D. from the internal table by pressing **enter** or to press the top softkey and enter your own D.D. for the current dive. For this tutorial, accept the D.D. from the Diving 5's table. For complete information on entering your own D.D.'s, refer to Chapter 3.

Follow the same procedure to enter dive information for the remaining 3 divers as listed on the following table:

Diver Number	Diver Name	Round 01 Dive	Round 02 Dive
Diver 02	BOB	112B	202B
Diver 03	JEFF	302A	205C
Diver 04	MIKE	202B	104C

Saving The Program

This completes programming the sample meet. Press **quit** to exit Program mode. The next screen prompts you to save the programmed meet. Press the **Yes** softkey, type a name for your sample program, for example, **TEST1**, in response to the next prompt, and press **enter** to save it.

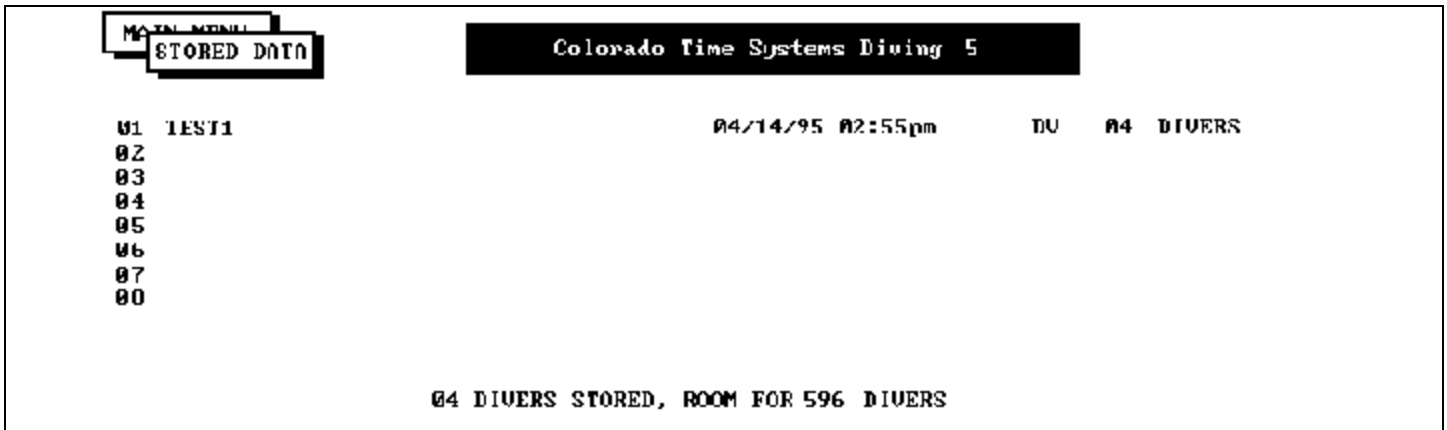

Figure 2-M Save Sample Event

The Stored Data screen shows you that the sample meet you have just programmed is stored in permanent memory. Press **quit** to return to the Options screen.

Running The Sample Meet

To begin the sample meet, press the **Retrieve Stored Data** softkey. Use the arrow keys to select the sample meet you just saved, and press **enter** to load it.

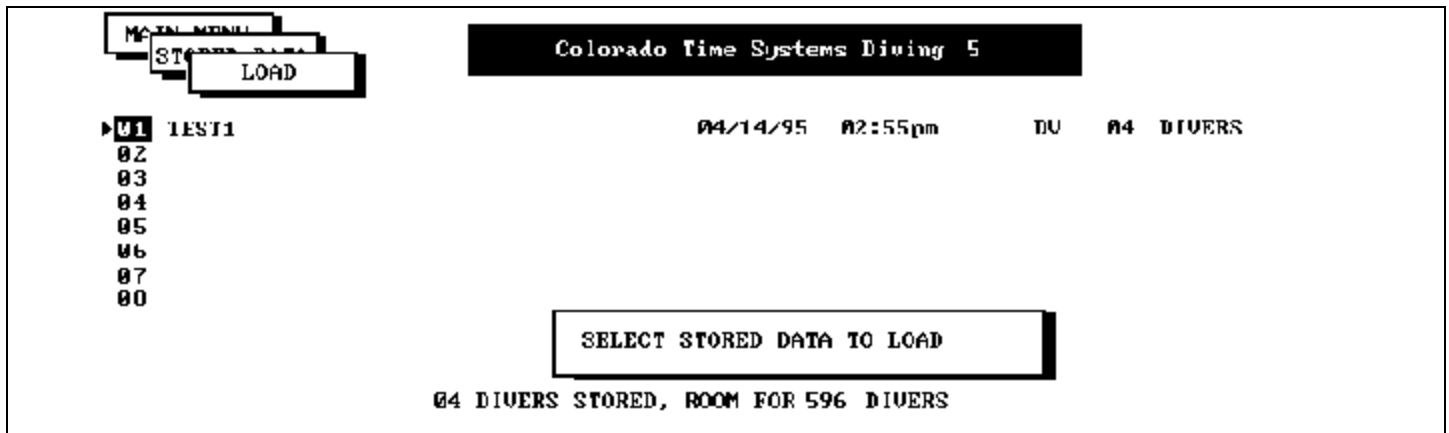

Figure 2-N Load Sample Event

The next screen prompts you to select the number of judges scoring the meet. Press the **5** softkey. Diving 5 automatically turns on the first five judges. You are now ready to run the sample meet.

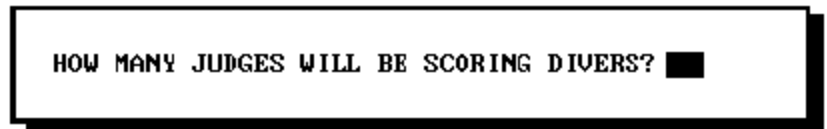

Figure 2-O Select Number of Judges with Softkeys

The Diving 5 Main screen prompts you to press **next dive** to begin running the meet.

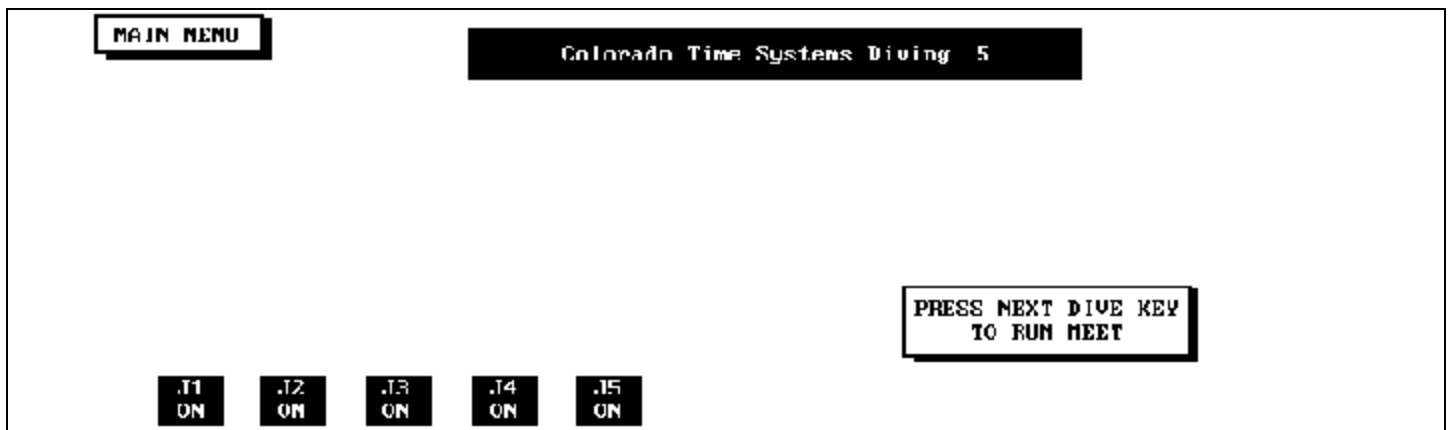

Figure 2-P Press **next dive** to Start the Meet

The Judging screen displays judging information. John's first dive and D.D. appear on the screen. At this point in a real meet, John would perform his dive and the judges would enter their scores. For the sake of simplicity in this tutorial, simply enter the indicated judges scores using the **scores** keys on the keyboard insert: **4.0**, **4.5**, **5.5**, **5.0**, and **4.5**. Diving 5 automatically begins with judge 1 and ends with judge 5 when you enter scores manually.

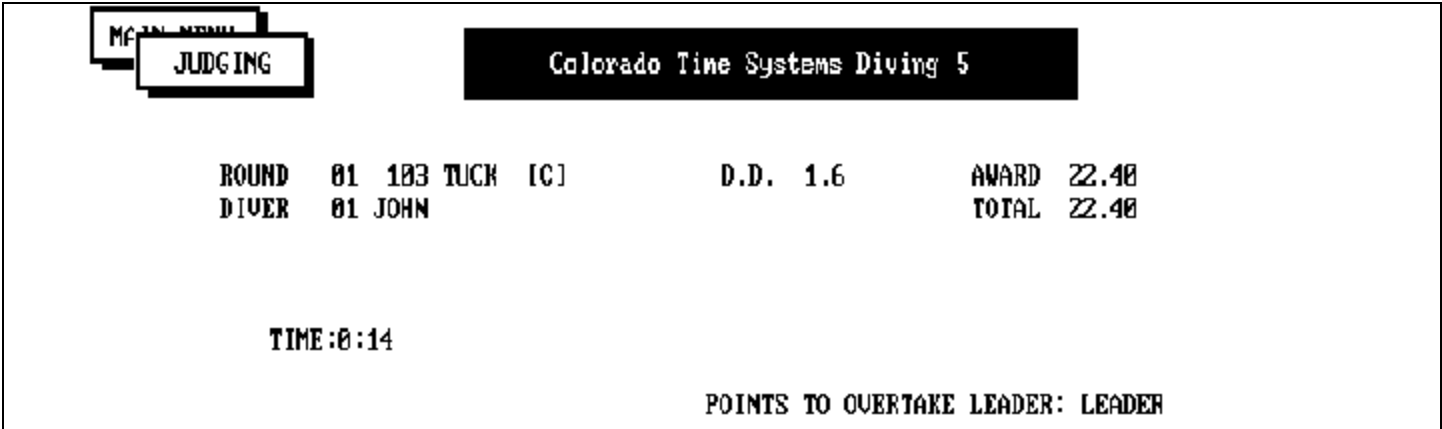

Figure 2-Q Sample Dive Judging Display

After entering all five scores, check the display to make sure the correct scores are displayed above each judge. Diving 5 sends the judges' scores, current dive award, and total score both to the scoreboard and printer automatically when the last judge's score is received. When you are satisfied that the scores are correct, press **next dive**.

X Note: If Diving 5 receives a judge's score that is not divisible by .5, the window shown in Figure 2-R appears on the judging screen. To accept the non-standard score, press **enter**. To reject the score, press **quit** and re-enter the score using either the Diving 5 keyboard or the appropriate judging terminal.

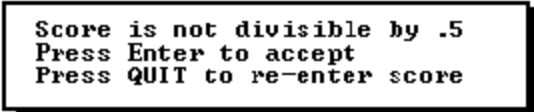

Figure 2-R Automatic Score Checking

You have now successfully completed one dive. Notice that the screen displays the number of points the current diver needs to overtake the leader. In this case, since John is the first diver, he is the leader. To continue the sample meet, repeat the process described above for the remaining divers as listed in the table below:

Diver	Round	Scores
Diver 02	Round 01	3.5, 4.0, 4.0, 4.5, 5.0
Diver 03	Round 01	4.0, 5.0, 5.5, 4.5, 5.0
Diver 04	Round 01	4.5, 5.0, 5.0, 4.0, 5.5
Diver 01	Round 02	5.0, 5.0, 6.0, 5.5, 4.5
Diver 02	Round 02	5.0, 5.0, 4.5, 5.5, 4.0
Diver 03	Round 02	3.5, 4.0, 3.5, 4.5, 5.0
Diver 04	Round 02	5.5, 6.0, 5.5, 5.0, 6.5

Saving The Completed Meet

To save your completed meet, including all scores, press **quit** and then press the **Stored Data** softkey from the Main softkey menu, Figure 2-S.







ENTER /EDIT		
DISPLAY		
PRINT		
STORED DATA		
SETUPS		
MISC.		

Figure 2-S Diving 5 Main Softkey Menu







LOAD EUEM		
SAVE EUFMT		
DELETE EUEM		
		
EXPORT EUFMT		
IMPORT EUEM		

Figure 2-T Diving 5 Stored Data Softkey Menu

From the Stored Data softkey menu, Figure 2-T, press the **Save Event** softkey. Type a name for the sample meet and press **enter** to save it. Your sample meet program is now stored in permanent memory. Deleting these sample meets is very easy using the **Delete Event** softkey. Refer to Chapter 3 for complete information on deleting events. This completes our sample meet.

This tutorial only covered the most basic of operating Diving 5. Feel free to try any of the more advanced features when running this tutorial. Take this opportunity to learn how to use Diving 5 before you actually run a meet.

Using Enter Data On The Fly Mode

To run the sample meet without a program, follow these steps.

X Note: To return to the Options menu, turn your System 5 off and on; re-enter Diving 5 as explained on pages 2-2 - 2-4.

1) Press the **Enter Data on the Fly** softkey. The first screen prompts you to select the number of judges scoring the meet. For

this tutorial, press the **5** softkey.

2) The next screen prompts you to select the number of divers in the meet. For this tutorial, press **4** on the numeric keypad and then press **enter**.

3) The next screen prompts you to select the event type. Use the arrow keys to select the desired event. For this tutorial, simply press **enter** to select the **1 Meter Springboard** event.

4) The Diving 5 Main screen now appears. Press **next dive** and follow the instructions on the Judging screen:

a) Enter the Dive Type and Position using the numeric keypad and position keys and then press **enter**. Diving 5 automatically posts the D.D. (Degree of Difficulty) for the dive if the dive type is in the Diving 5's internal table. If not, Diving 5 prompts you to enter the D.D. for the dive. Type the D.D. using the numeric keypad and press **enter**.

X Note: To speed data entry, you can skip the Dive Type and simply enter the D.D. Press **enter** to skip the Dive Type field.

b) Enter the individual judges' scores using the **scores** keys on the keyboard insert.

5) Press **next dive** to advance to the next diver.

6) Repeat this process until all dives are completed. Use the sample dive data in this chapter to practice running a meet. If you are running a real meet in Enter Data on the Fly mode, you can use the Judging terminals to enter scores as usual.

REFERENCE

This chapter describes in detail the operation of the Diving 5 program, the function of each key on the keyboard, and all softkey functions. Screen display examples appear as appropriate. This chapter is not meant to be read from beginning to end. Instead, use it as a reference to learn about individual features and functions of Diving 5. To locate specific information quickly, look up the desired feature in the Index or Table of Contents. For general information about your System 5 Sports Timer, refer to the *Swimming 5 User Guide*.

Self-Test/Loading Diving 5

Summary

The Self-Test screen is the first screen you see when you turn on your System 5. After the self-test is complete, you can load any of the sports programs installed on your System 5.

Operation

When you turn on your System 5, it performs a series of self-test. If any of these tests fail, the Test/Programming menu is displayed along with an indication of which test failed. Follow the instructions on the screen to conduct further tests and troubleshooting. Refer to Appendix B of your *Swimming 5 User Guide* for complete instructions on using the Test/Programming menu. If a test fails after you have tried all the recommended remedies, call Colorado Time Systems' Customer Service Department at (800) 287-0653 (US and Canada) or (970) 667-1000 (international).

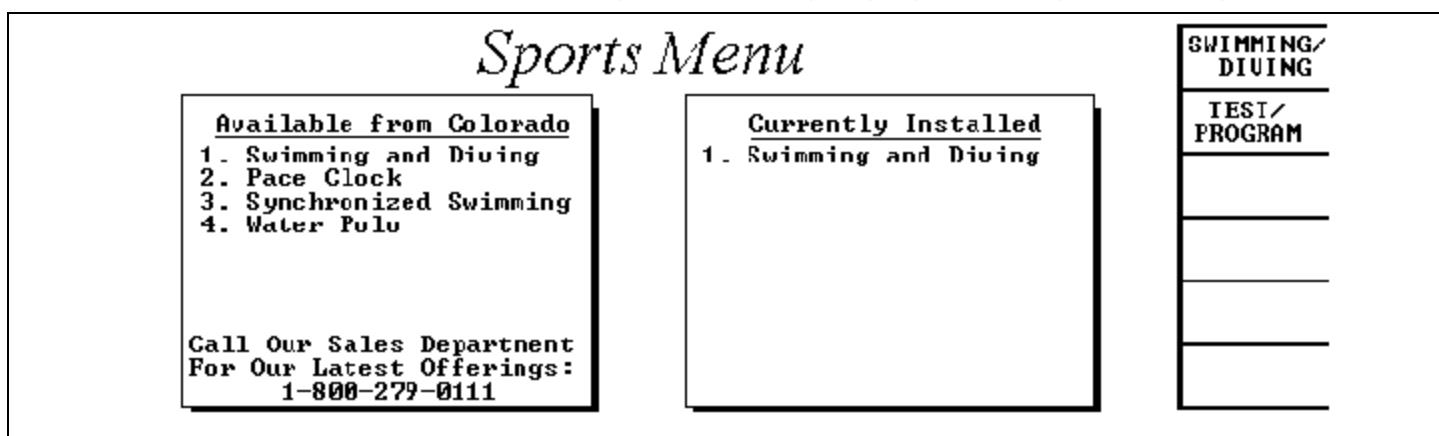

Figure 3-A Sports Menu

After the self-tests are completed, the Sports Menu appears. The Sports menu displays the sports software available from Colorado Time Systems and the sports programs currently installed in your System 5. Press the **Swimming/Diving** softkey.

PRINT	⬡
DISPLAY	⬡
SCORE BOARD	⬡
SETUPS	⬡
STORED DATA	⬡
MISC	⬡

Figure 3-B Swimming 5 Main Softkey Menu

When Swimming 5 loads, press the **Misc** softkey from the Swimming 5 Main softkey menu.

PADPOWER ON/OFF	⬡
RUN DIVING	⬡
	⬡
	⬡
	⬡
	⬡

Figure 3-C Swimming 5 Misc Softkey Menu

From the Misc softkey menu, press the **Run Diving** softkey and then press the **Yes** softkey in response to the confirmation box. In a few seconds, Diving 5 loads and is ready to use. Refer to the Softkeys section of this chapter for instructions on using Diving 5 softkeys.

Display Screen

Summary

Diving 5 uses the System 5 Sports Timer LCD (Liquid Crystal Display) screen to communicate with you.

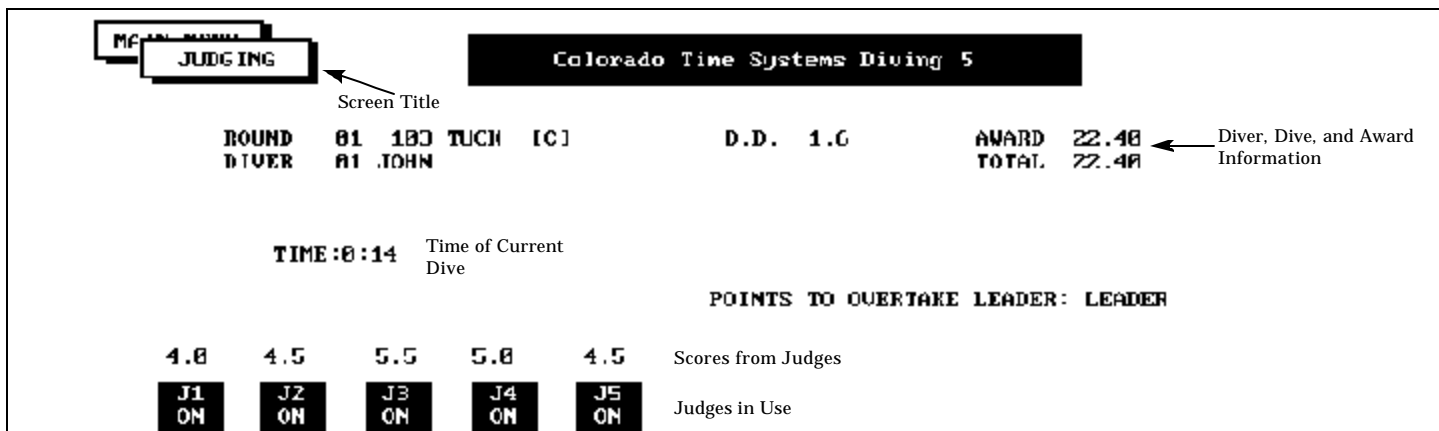

Figure 3-D Diving 5 Main Judging Screen

Operation

Diving 5 uses the LCD screen to communicate a wide range of information. The locations of these displayed items are indicated on the display screen example, Figure 3-D.

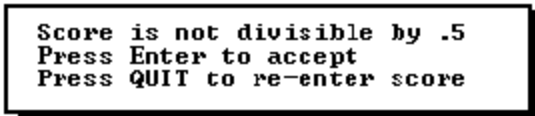

Figure 3-E Automatic Score Checking

X Note: If Diving 5 receives a judge's score that is not divisible by .5, the window shown in Figure 3-E appears on the Judging screen. To accept the non-standard score, press **enter**. To reject the score, press **quit** and re-enter the score using either the Diving 5 keyboard or the appropriate judging terminal.

Keyboard

Summary

This section describes the function of the keys on the Diving 5 keyboard insert. The keys are described in order as they appear from left to right on the keyboard. Refer to the Index to locate a specific key description quickly. References to keyboard keys appear in **bold italic** type in this manual.

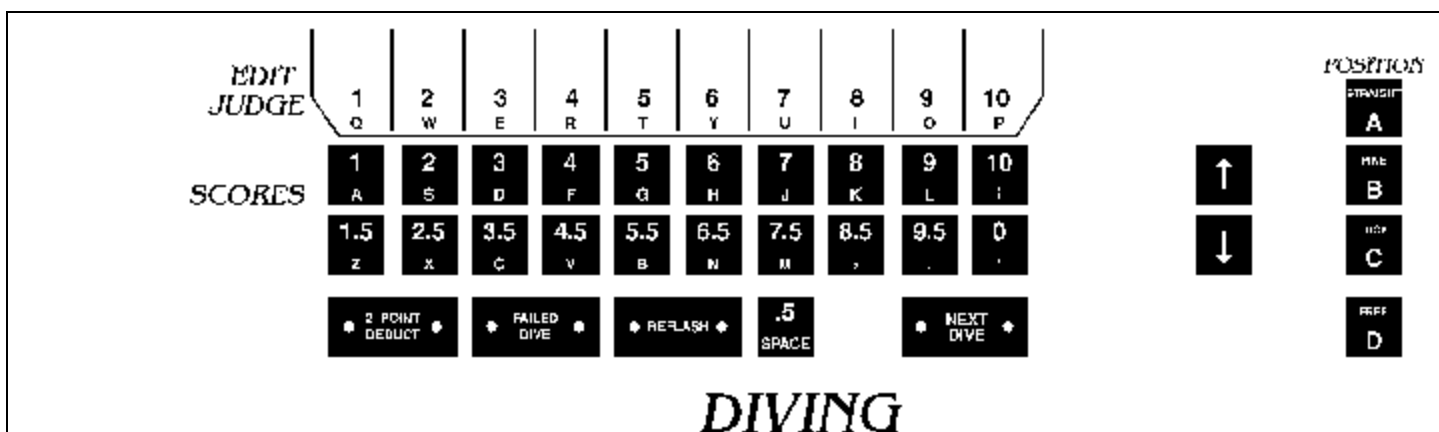

Figure 3-F Diving 5 Keyboard Insert

Alphabetic Keys

Function



The alphabetic keys occupy the top three rows of the Diving 5 keyboard. They are arranged in standard typewriter order. Use these keys to enter names of divers, programs, etc., when Diving 5 prompts you to do so.

Operation

As with all keys on the Diving 5 keyboard, press firmly to enter a letter with the alphabetic keys.

Edit Judge

Function

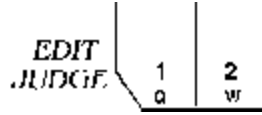

These keys have two functions. First, they turn on or off the judging terminals. Second, the **edit judge** keys allow you to edit a judge's score which was entered in error.

Operation

1) To turn judging terminals on or off, press the **Setups** softkey. As indicated by the note on the display screen, press the appropriate **edit judge** keys to turn on or off the desired judging terminals.
2) To edit a judge's score entered in error, after a dive but before you press **next dive**, press the desired **edit judge** key and press either the appropriate **scores** key or use the numeric keypad to enter the correct score. If you use the numeric keypad to edit the score, press **enter** to accept the new score.

Scores

Function



Allows you to enter or edit judges' scores from the Diving 5 keyboard insert. If no judging terminals are attached, use these keys to enter the judges' scores. **Do not use the numeric keypad to enter scores.**

Operation

At any time when you are allowed to enter or edit judges' scores, such as during a dive when no judging terminals are attached or when using the **Enter/Edit** softkey to edit scores, press the desired key to enter the correct score.

2 Point Deduct

Function



Deducts two points from each judge's score. Diving 5 recalculates the award and automatically displays the new information on the scoreboard.

Operation

Press this key during the current dive, **before** you press **next dive**. Diving 5 automatically deducts two points from each judge's score.

Failed Dive

Function



In the event of a failed dive, press this key to record a score of **0.0** for each judge.

Operation

To record a failed dive, press this key during the current dive, **before** you press **next dive**. All scores are set at **0.0** and are automatically sent to the scoreboard.

Reflash



Function

Allows you to edit dive information including scores and blanks the scoreboard for the current dive.

Operation

During the current dive, **before** pressing **next dive**, press **reflash** to edit the dive. Diving 5 clears all scores from the display screen, but not from temporary memory. You can reenter judges scores or press one of the edit dive softkeys. By pressing the appropriate softkey, you can edit the D.D., re-dive, automatically send the dive information to the scoreboard and printer at the completion of each dive, or send that information manually. Refer to pages 3-13 - 3-15 for instructions on using these softkeys. Press the desired **scores** key(s) to enter the correct scores.

Press **quit** to exit without making any changes or press **next dive** to store changes and continue to the next dive.

Space



Function

This key is the equivalent of the space bar on a computer keyboard. Press **space** when you need to enter a space while typing a name or other information.

Operation

Press this key to enter a space at the current cursor position.

Next Dive



Function

This key tells the Diving 5 program that the current dive is completed. Diving 5 then computes awards, displays the information on the scoreboard, and proceeds to the next dive in the sequence. If you entered dive information before the competition began, the next dive appears on the screen, otherwise you are prompted to enter information for the next dive. If you press this key before entering any dive information, the following message appears on the display screen:

You Must Either:
Enter the Number of Divers
OR
Enter the Dives for This Session
Before Pressing the "Next Dive" Key
Press Any Key to Continue

If you see this message, you must either load a saved diving program or enter diving information for the current session. Refer to the Stored Data softkey section later in this chapter for instructions on loading a saved program. To enter information for the current session, begin by pressing the **Setups** softkey, and then press the **# of Divers** softkey from the Setups softkey menu. Type the number of divers in the current session and press **enter**. Refer to the Tutorial section of Chapter 2 for instructions on programming a diving session from the beginning. Pressing **next dive** also makes available the three softkeys described under **reflash** above.

Press this key when all information for the current dive is complete

Operation

and you are ready to progress to the next dive. This is a double key, meaning you must use two fingers to press both white dots on this key.

Up And Down Arrow Keys



Function

The **up** and **down** arrow keys move the highlight bar on the display screen up or down, allowing you to select the desired line on the screen.

Operation

To move the highlight bar up, press the **up** arrow key. To move the highlight bar down, press the **down** arrow key.

Position Keys

POSITION



Function

These four keys allow you to enter the position for each dive. When you enter a dive number, you must also press a position key for the dive. The letter corresponding to the position you pressed is added to the dive number.

Operation

After entering a dive number, press the desired position key.

Numeric Keypad

KEYPAD

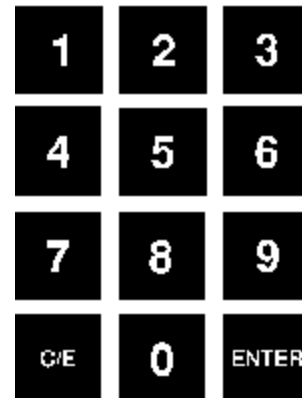

Function

Allows you to enter numbers in response to a variety of prompts.

Operation

There are many instances during the operation of Diving 5 when it is necessary to enter numbers. Whenever a numeric entry is required, use the keypad to make the desired entry.

C/E (Clear Entry)



Function

Allows you to clear an entry made in error. You must press this key before pressing **enter**, which accepts and entry.

Operation

Press **c/e** to clear one character at a time from an entry field.

Enter



Function

Enters the numeric or other keyboard entry into Diving 5. This key works exactly like the **enter** key located on the numeric keypad on the System 5 lower console. You may press either **enter** key to accept any entry.

Operation

After typing numbers or letters, press **enter** to accept the entry.

Console Keys

The console keys are located to the right of the LCD display screen. The console keys are shown in Figure 3-G.

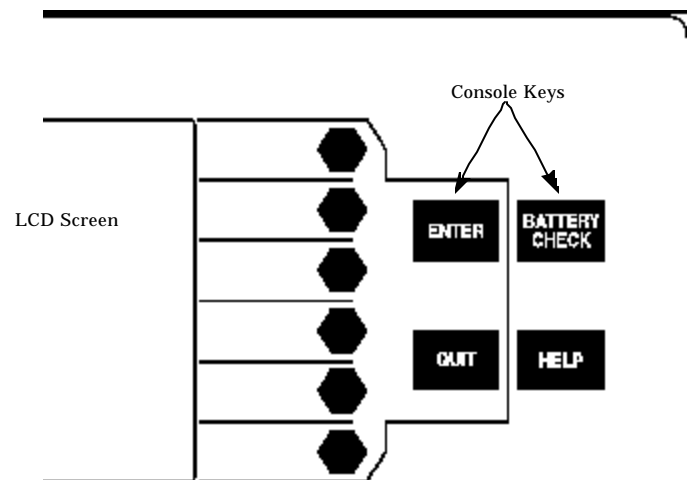

Figure 3-G Console Keys

Enter



Function

Enters the numeric or other keyboard entry into Diving 5. This key works exactly like the **enter** key located on the numeric keypad on the System 5 lower console. You may press either **enter** key to accept and entry.

Operation

After typing numbers or letter, press **enter** to accept the entry.

Quit



Function

Allows you to leave a Diving 5 function without saving data entered, or to exit the current prompt when pressing **enter** does not do so.

Operation

Press **quit** to exit a prompt after entering data. This key also

allows you to cancel an operation that requires an entry without changing the current setting. No information is entered if you press **quit** before pressing **enter**.

Battery Check



Function

This key allows you to display the estimated percentage of battery power left on both the primary and secondary sources in the computer. The battery life display is only available on the main timing screen.

Operation

Press **battery check** to display a window which contains the estimated percentage of battery life remaining. The power source currently in use is also displayed. A low reading, 20% or less, for either battery source indicates that the appropriate batteries must be replaced soon. Use only alkaline batteries to obtain the most accurate battery check information.

X Note: If you are going to store your System 5 for over 30 days, remove the batteries to prevent possible damage to your System 5.

Help

The Diving 5 program does not include any help information. The **help** key is therefore inactive.

Softkeys

Summary

This section describes the operation of the Diving 5 softkeys. The softkeys are the column of six unlabeled keys to the immediate right of the screen. The function of each key varies depending on the operation selected. The screen displays the function currently available directly to the left of each softkey. If no label appears next to a softkey, that key is inactive. References to softkeys appear in Capitalized **Bold Italic** type in this manual. Figure 3-H shows the Diving 5 Main softkey menu.

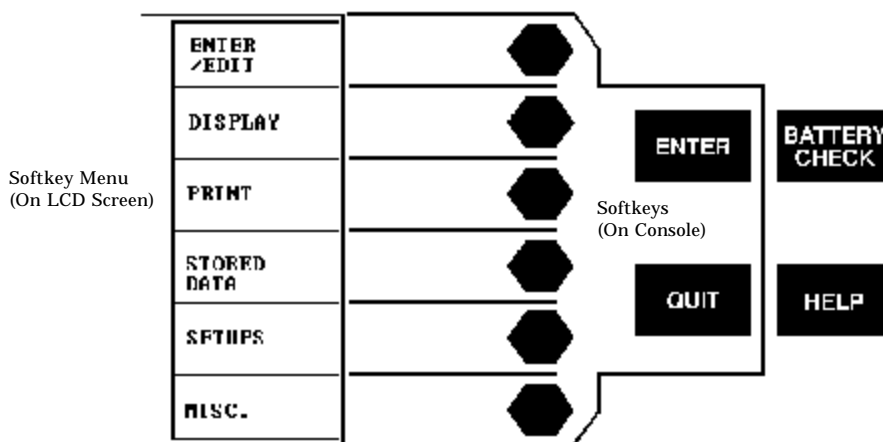

Figure 3-H Diving 5 Main Softkey Menu

Operation

Each softkey's functions are organized in layers or levels. The first level consists of the six softkeys displayed in the Main softkey menu. When you press one of these softkeys, a second level offering more specific choices is displayed. In general, pressing a second level softkey executes an action or prompts you to enter data.

If you press a softkey by mistake, or want to return to the main screen after using a softkey, press **quit**. If you have not pressed **enter** after typing an entry, pressing **quit** exits without saving that entry.

Options Screen Softkeys

Summary

When you first run Diving 5, the Options screen and softkey menu are displayed. The screen gives a brief description of the available softkey options. These options allow you to retrieve diving data from memory, program a new diving sequence for a meet, enter diving data “on the fly” as the meet progresses, or return to Swimming.

RETRIEVE STORED DATA		⬢
PROGRAM NEW DATA		⬢
ENTER DATA ON THE FLY		⬢
RETURN TO SWIMMING		⬢
		⬢
		⬢

Figure 3-1 Options Screen Softkey Menu

Press the desired softkey to begin using Diving 5. If you want to go directly to the Diving 5 Main screen, press **quit**.

X Note: Pressing **quit** bypasses all pre-meet data entry, which must then be done manually using the **Setups** softkey. It is generally better to select one of the softkeys on the Options softkey menu before running a diving meet.

Retrieve Stored Data

Summary

The **Retrieve Stored Data** softkey allows you to load a stored diving sequence programmed in advance of the meet, or data from a completed meet which you want to edit or print. Pressing this softkey displays the Stored Data screen, ready to load a stored Diving program.

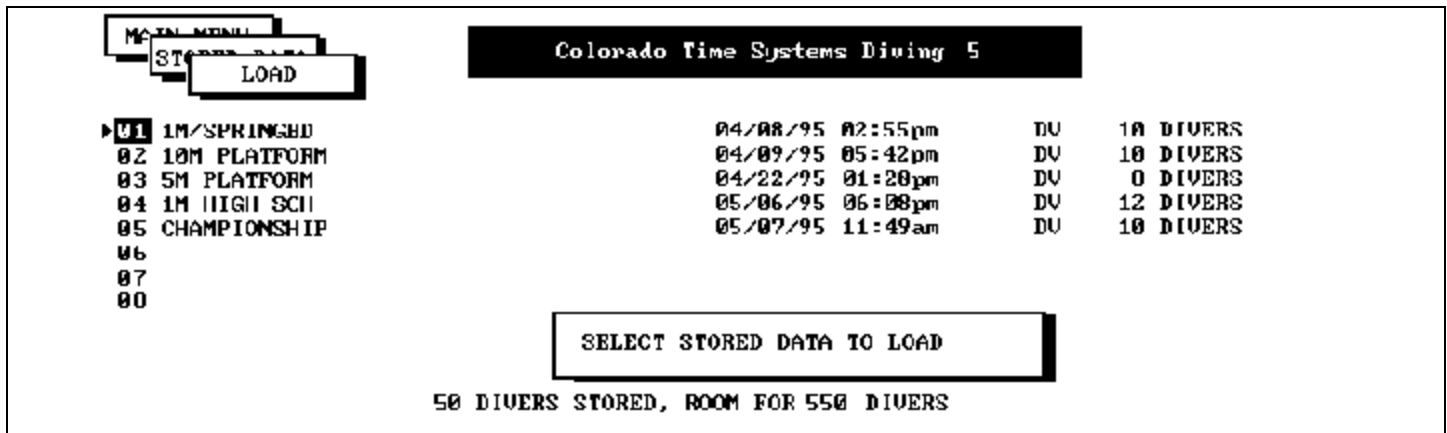

Figure 3-J Load Event Selection Screen

Operation

Press the **Retrieve Stored Data** softkey to load a diving sequence or completed meet data from memory. The Stored Data screen prompts you to select the data to load. Press the **up** or **down arrow** key to highlight the number of the desired Diving data. Press **enter** to load.

X Note: Only data marked **DV** for Diving can be loaded into Diving 5. Other data sharing memory space with Diving cannot be loaded.

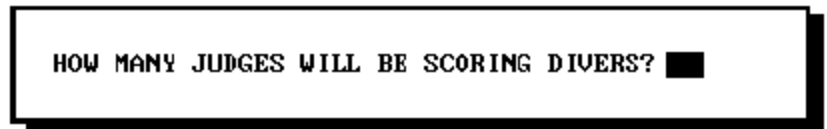

Figure 3-K Select Number of Judges to Score Meet

The next screen prompts you to select the number of judges used to score divers in the upcoming meet. Press the softkey labeled with the desired number. Diving 5 then returns to the Main screen with the selected number of judges turned on automatically. You are now ready to run the meet or edit data stored from a completed meet.

Program New Data

Summary

Press this softkey to program new diving meet information in advance of the competition. You can then save the program for retrieval at the time of the meet. Using a pre-programmed sequence for a diving meet speeds and simplifies your job during the meet, but requires more work beforehand to program all dives for each diver competing in the meet. Diving 5 automatically recalls the programmed data for each diver and dive during the meet.



Figure 3-L Select Event Type

Operation

Press the **Program New Data** softkey. The next screen prompts you to select the event type for the meet. Use the **up** or **down arrow** keys to highlight the desired event type and press **enter**.

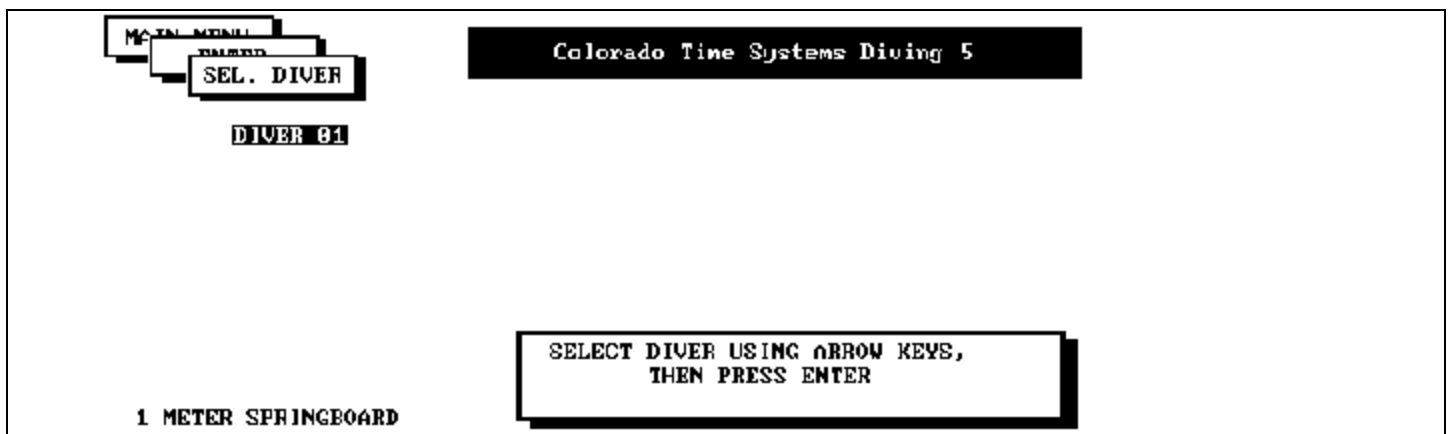

Figure 3-M Select Diver Number

The next screen prompts you to select the diver number for which to program dive information. Use the **up** or **down arrow** keys to highlight the desired diver number and press **enter**. The following screen (not shown) prompts you to enter the name of the swimmer. Type the swimmer's name and press **enter**.

The next screen first prompts you to select the Round number for the dive to be programmed. Use the **up** or **down arrow** keys to highlight the desired round number and press **enter**. Then type the dive type and position using the numeric keypad and position keys, for example, **103C**. When you finish typing the dive number and position, Diving 5 prompts you to accept the D.D. from the internal table by pressing **enter** or to press the top softkey and enter your own D.D. for the current dive using the numeric keypad.

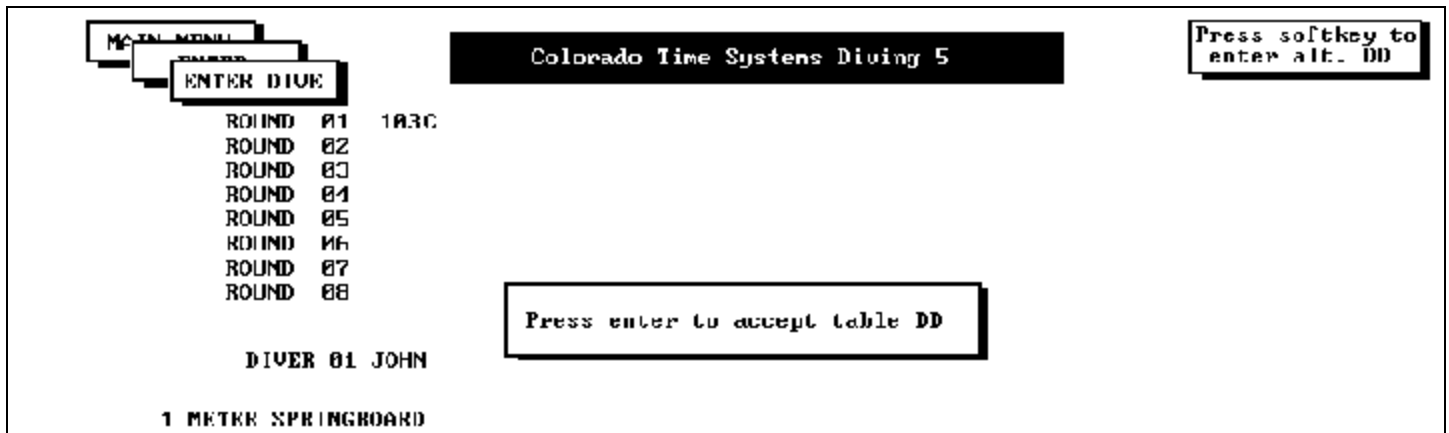

Figure 3-N Enter Dive Type and Position

If you choose to accept the D.D. from the internal table, Diving 5 automatically posts the D.D. for that dive. If you enter a dive that is not in Diving 5's internal table, an error message prompts you to re-enter the dive. Press **quit**, type the dive number and position, press the top softkey, and enter the D.D. for the dive using the numeric keypad and press **enter**.

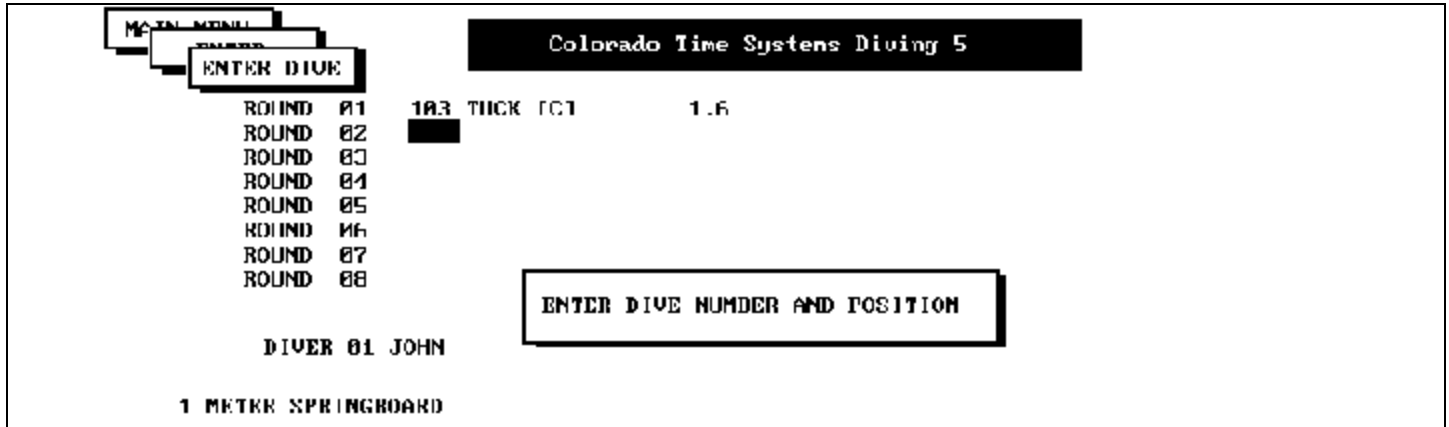

Figure 3-O Press **enter** to Accept Table DD

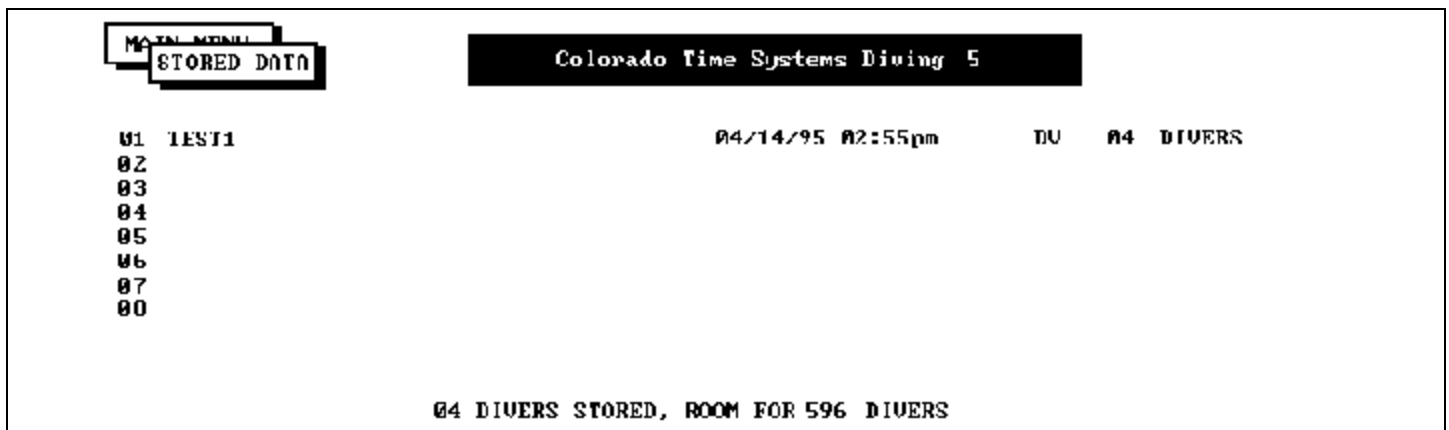

Figure 3-P Save Meet Data

When you are finished entering diver and dive data, press **quit**. The next screen prompts you to save the programmed meet. Press the desired softkey in response. If you choose to save the meet data you just entered, type a name for the diving program and press **enter** to save it. Use the **Retrieve Stored Data** softkey to load the saved meet information when you are ready to run the meet.

Enter Data On The Fly

Summary

This option allows you to run a meet manually - without a program - by entering dive data as the meet progresses. This option requires much more data input during the meet, including all data for each dive, but is very quick and needs no pre-programming.

Operation

Press the **Enter Data on the Fly** softkey to begin the meet. The next screen prompts you to select the number of judges scoring the meet. Press the desired softkey to select the number of judges.

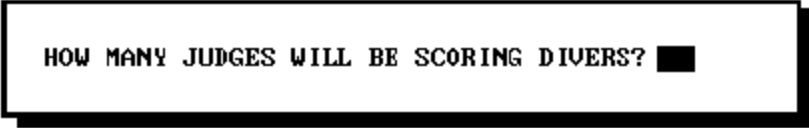

HOW MANY JUDGES WILL BE SCORING DIVERS? ■

Figure 3-Q Select Number of Judges to Score Meet

The next screen (not shown) prompts you to enter the number of divers participating in the meet. Type the desired number using the numeric keypad and press **enter** to continue. The next screen prompts you to select the event type. Use the **up** or **down arrow** key to highlight the desired event and press **enter** to select it.



Figure 3-R Select Event Type

The Diving 5 Main screen now appears. Press **next dive** when the first diver is preparing to dive. The display prompts you to enter the dive type and position. Enter this information using the numeric keypad and position keys. If the dive type entered appears in Diving 5's database, the D.D. is posted automatically. If not, you must type the D.D. using the numeric keypad and press **enter**.

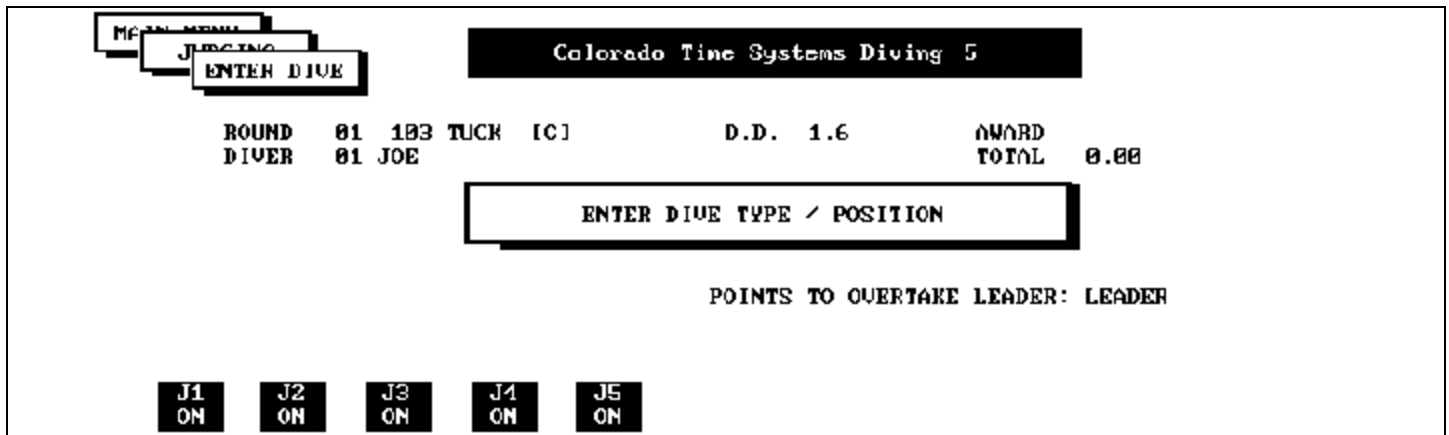

Figure 3-S Enter Dive Type and Position

X Note: To speed data entry, you can skip the Dive Type field and simply enter the D.D. Press **enter** to skip the Dive Type Field.

After all judge's scores have been received, press **next dive** to advance to the next diver. Repeat this procedure until all dives are completed.

Return to Swimming

Summary

This softkey allows you to return immediately to Swimming. This selection is especially useful if you ran Diving 5 by mistake.

Operation

Press the **Return to Swimming** softkey. Swimming reloads in a few seconds.

Judging Softkeys

Summary

The judging softkey menu appears when you press either **reflash** or **next dive** on your Diving 5 keyboard insert, putting Diving 5 into Judging mode. The softkeys on this menu allow you to edit the D.D., re-dive, and choose whether to have Diving 5 automatically send dive results to the scoreboard and printer after each dive.

CHANGE DIVE/DD	●
RE-DIVE LAST	●
HOLD →SEND	●
	●
	●
	●

Figure 3-T Edit Dive Softkey Menu

Operation

Read the descriptions of the **reflash** and **next dive** keys earlier in this chapter and in the Tutorial section of Chapter 2 for a full explanation of the use of these keys. When you press either of these keys, the Dive Edit softkey menu appears on the display screen.

X Note: The Edit Dive softkey menu is only available **before** the judges' scores are entered. The only way to change the D.D. after scores have been entered is to press **reflash**, edit the D.D., and re-enter the judges' scores for the dive.

Change Dive/DD

Function

Allows you to change the D.D. for the current dive.

Operation

Press this softkey, type the correct D.D. using the numeric keypad, and press **enter**. The new D.D. appears on the display screen and scoreboard.

Re-Dive Last

Function

Press this softkey to re-dive the previous dive. All scores for the previous dive are cleared.

Operation

Press this key to re-dive the previous dive. The dive can now be repeated and new scores entered.

Hold/Send

Function

Allows you to select whether to hold diving scores from automatic printing and display on the scoreboard. If the selection arrow points at **Hold**, each time you press **next dive**, the bottom softkey appears, prompting you to **Send** scores to the scoreboard and printer. This is a useful feature if you want to check all judges scores before sending them to the scoreboard and printer.

If the selection arrow points at **Send**, all scores are automatically sent to the scoreboard and printer when you press **next dive**. The default mode is **Send**.

Operation

Press this softkey to move the selection arrow from **Hold** to **Send**. Repeat to move the selection arrow again. No further action is necessary. The selected mode takes effect immediately.

Enter/Edit



Summary

The **Enter/Edit** softkey allows you to enter all diving information necessary to conduct a meet. You can either enter information for a meet you are about to begin, or you can enter information at any time before the meet and save it as a diving program using the **Stored Data** softkey.

ENTER DIVES		⬢
EDIT DIVES		⬢
MOVE DIVERS		⬢
EDIT DD TABLE		⬢
PRINT DD TABLE		⬢
ALPHA EXPORT		⬢

Figure 3-U Enter/Edit Softkey Menu

Operation

Press this softkey to access the Enter/Edit softkey menu. The softkeys on this menu provide access to all features for entering and editing diving information.

Enter Dives

Function

Allows you to enter diving information for all divers in a meet, including the event type, diver's names, dive number and position.



Figure 3-V Select Event Type

Operation

Press the **Enter Dives** softkey to enter diver and dive information. The display first prompts you to select the event type as shown in Figure 3-V. Use the **up** or **down** arrow key to highlight the desired event and press **enter**.

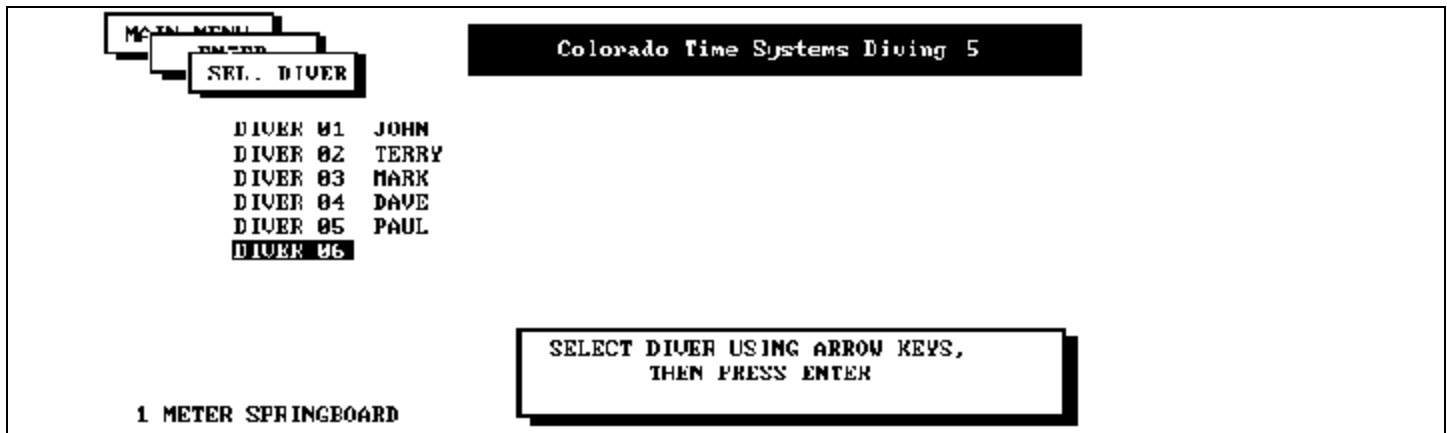

Figure 3-W Select Diver Number

The next screen prompts you to select the diver to enter dives for, Figure 3-W. Use the **up** or **down** arrow keys to highlight the desired diver number and press **enter**.

The next screen (not shown) prompts you to type the name of the diver. Type the name and press **enter**. The following screen prompts you to select the round for the dive you are entering. Use the **up** or **down** arrow key to highlight the desired round number and press **enter**.

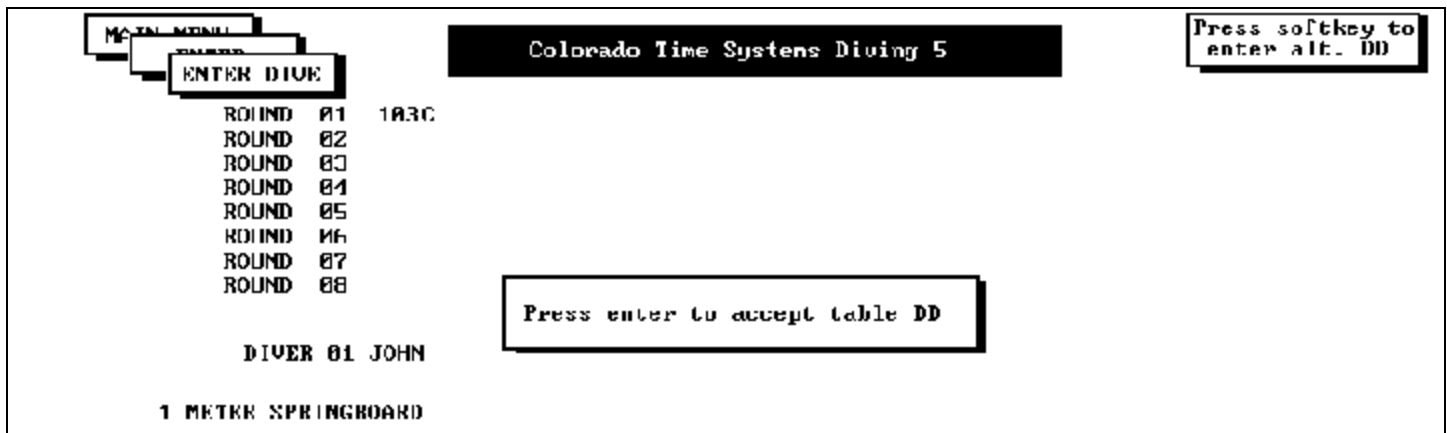

Figure 3-X Enter Dive Type and Position

Next, as shown in Figure 3-X, type the dive type and position using the numeric keypad and position keys, for example, **103C**. When you finish typing the dive number and position, Diving 5 prompts you to accept the D.D. from the internal table by pressing **enter** or to press the top softkey and enter your own D.D. for the current dive using the numeric keypad.

If you choose to accept the D.D. from the internal table, Diving 5 automatically posts the D.D. for that dive. If you enter a dive that is not in Diving 5's internal table, an error message prompts you to re-enter the dive. Press **quit**, type the dive number and position, press the top softkey, and enter D.D. for the dive using the numeric keypad and press **enter**.

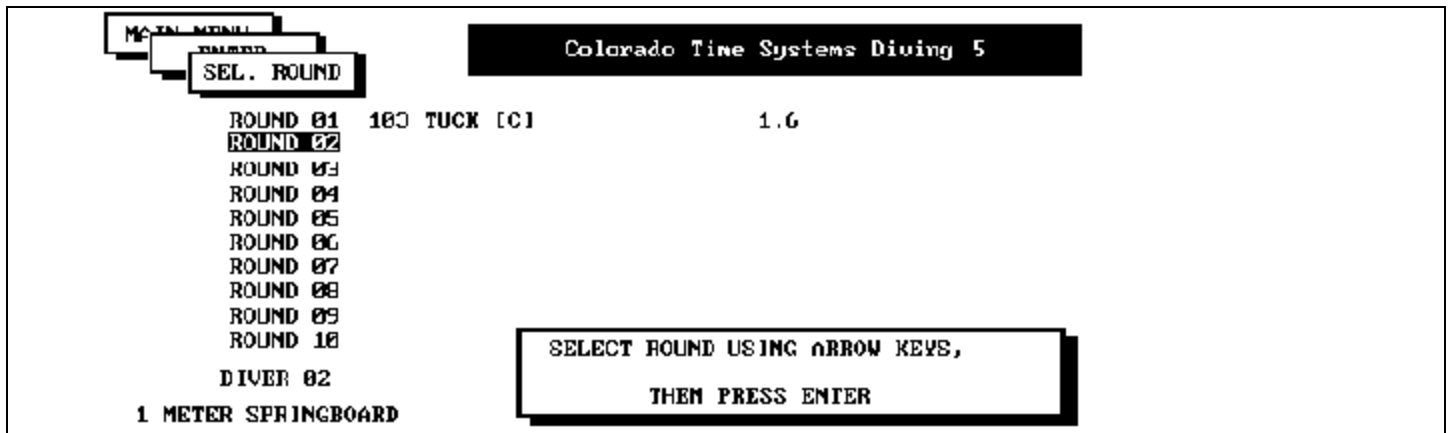

Figure 3-Y Select Round Screen

Repeat the process to enter all the dives for the current diver. Press **quit** when you are done entering dive information for the currently selected diver. Diving 5 again prompts you to select the diver to enter dives for, using the screen shown in Figure 3-Y. Select the desired diver and repeat the process explained here to enter diving information for all divers in the meet. When you are done entering all information, Diving 5 is fully programmed for the meet.

X Note: Do not forget to use the **Stored Data** softkey to save in permanent memory the diving program you just entered. If you turn off your System 5 before saving a program, that program is lost.

Edit Dives

Function

This softkey allows you to edit all dive information for any diver in the current session.

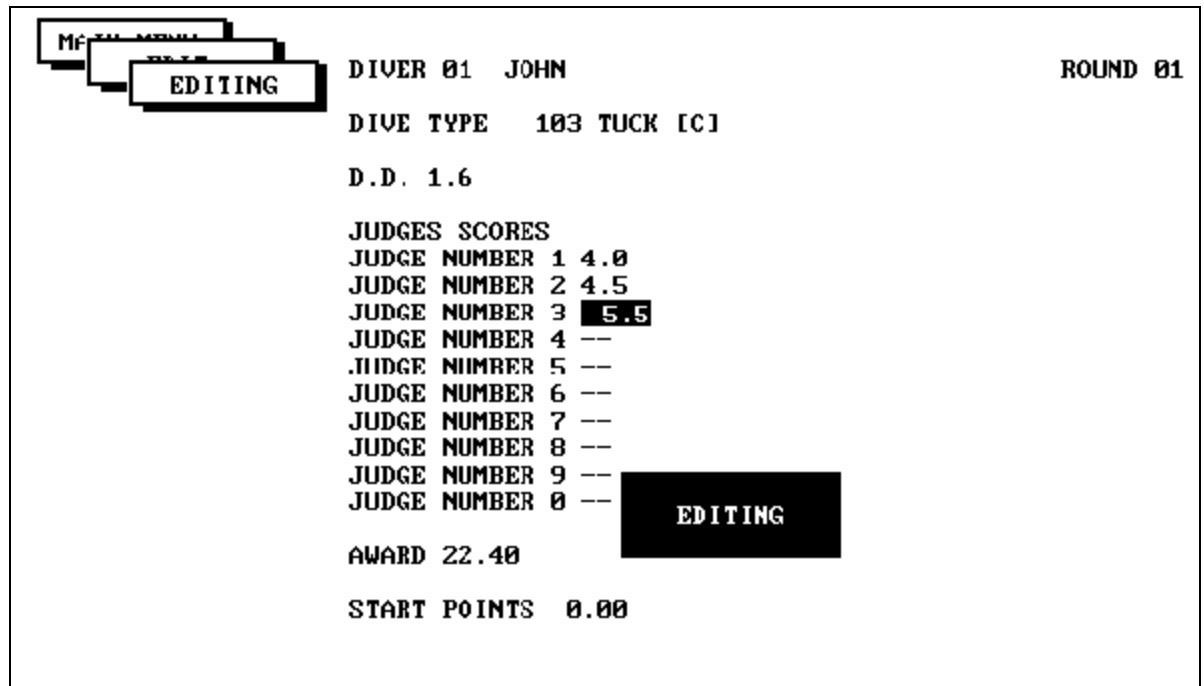

Figure 3-Z Edit Dives Screen

Operation

Press the **Edit Dives** softkey. The display prompts you to select the diver whose dive(s) you want to edit. Highlight the desired diver using the **up** or **down** arrow keys and press **enter**. The next screen prompts you to select the round to edit. Highlight the desired round using the **up** or **down** arrow key and press **enter**. The next screen, shown in Figure 3-Z, displays all current information in memory for that diver. To edit the information, use the **up** or **down**

arrow key to highlight the desired information and press **enter** to access edit mode. Type the desired information in the highlighted field and press **enter** when done. Repeat the process to edit diver information as needed. Press **quit** when done.

Move Divers

Function

Allows you to change the order of the divers on the session list. Pressing this softkey displays the Move Divers softkey menu.

Operation

Press this softkey to display the Move Divers softkey menu. Select the desired operation from this menu. The actions of the available softkeys are described below.

MOVE DIVER		⬇
RANDOM ORDER		⬇
INSERT DIVER		⬇
DELETE DIVER		⬇
		⬇
		⬇

Figure 3-AA Move Divers Softkey Menu

Move Diver

Function

Moves a diver and all associated dives to a location on the list you specify.

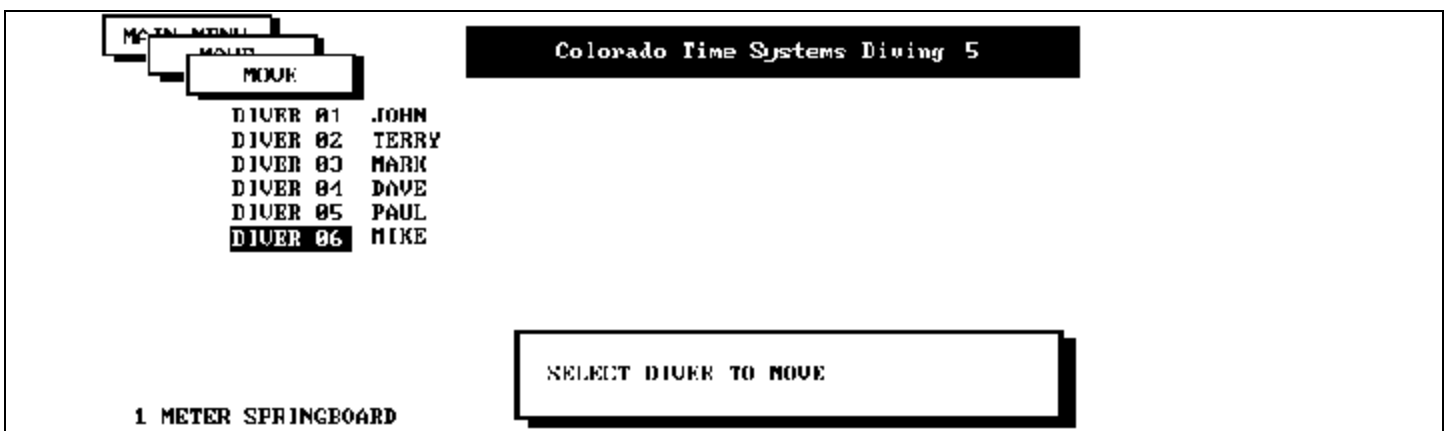

Figure 3-AB Move Diver Screen

Operation

Press this softkey to move a diver. Highlight the diver you want to move using the **up** or **down** arrow key and press **enter**. Use the **up** or **down** arrow key to move the highlight bar to the desired new location in the list for the selected diver and press **enter**. The selected diver moves to the new location. All divers below the new position move down one.

Random Order

Function

Puts all divers on the current list into random order.

Operation

Press the **Random Order** softkey and then press **enter** to put all divers on the current list into random order.

Insert Diver

Function

Allows you to insert a diver into the current list.

Operation

Press this softkey to insert a new diver. Use the **up** or **down** arrow key to highlight the number for the new diver and press **enter**. If the number you select is currently occupied by a diver, that diver and all below move down one number. You can now use the **Enter Dives** softkey to enter dive information for the new diver.

Delete Diver

Function

Deletes a diver and all diver's dives from the current list.

X Caution: Be sure you have selected the correct diver before deleting. Unless you have saved the current diving event in permanent memory, any deletions you make are permanent.

Operation

Press the **Delete Diver** softkey, use the **up** or **down** arrow key to highlight the diver you want to delete and press **enter**. The selected diver is deleted from the current list.

Edit DD Table

Function

Allows you to search for dives and edit the D.D. (Degree of Difficulty) Table in the Diving 5 database. You can change the D.D. assigned to a dive, add new dives, remove un-needed dives, or return the D.D. table to its factory default status. Pressing this softkey displays a new softkey menu.

MAIN MENU		Colorado Time Systems Diving 5						
EDIT DD'S		1M.	3M.	5M.	7.5M.	10M.	1M.	HS.
DIVE TYPE								
001 FREE [D]			1.0					
002 FREE [D]			1.0					
100 STRAIGHT [A]	1.0	1.0						
100 PIKE [B]	1.0	1.0						
100 TUCK [C]	1.0	1.0						
101 STRAIGHT [A]	1.4	1.6	1.4	1.6	1.6	1.4		
101 PIKE [D]	1.3	1.5	1.3	1.5	1.5	1.3		
101 TUCK [C]	1.2	1.4	1.2	1.4	1.4	1.2		
102 STRAIGHT [A]	1.6	1.7	1.6	1.7	1.8	1.6		
102 PIKE [B]	1.5	1.6	1.5	1.6	1.7	1.5		
102 TUCK [C]	1.4	1.5	1.4	1.5	1.6	1.4		
103 STRAIGHT [A]		1.9	2.0	1.9	1.9			

Search for dive:

Figure 3-AC Edit DD Screen

Operation

Press this softkey to edit the D.D. Table in the Diving 5 database. Type the dive number and position you want to edit. Diving 5 automatically selects that dive if it exists in the D.D. Table. New softkeys provide access to the editing functions. The functions of these softkeys are described below. Use the arrow keys on the Diving 5 keyboard insert to select the dive type you want to edit. Use the arrow softkeys to select the dive height/type to edit.









DEFAULT DD TABLE		
ADD DIVE		
REMOVE DIVE		
EDIT DD		
		
		

Figure 3-AD Edit DD Softkey Menu.

Default DD Table

Function

Returns the D.D. table to its factory default status.

Operation

To return the D.D. table to its factory default status, press this softkey and then press **enter** in response to the confirmation box at the bottom of the screen. All changes made to the D.D. table are reset.

Add Dive

Function

Adds a dive to the D.D. table. Diving 5 places the new dive at the end of the current D.D. table

Operation

Press this softkey to add a new dive to the D.D. table. A box prompts you to type the dive number and position using the numeric keypad and position keys on the Diving 5 keyboard insert. When finished entering the new dive, press **enter** to place it in the D.D. table. To add D.D.'s for the new dive, use the **Edit DD** softkey as described below.

X Note: If you enter a dive number and position that

is always ready in the DD Table, Diving 5 highlights that dive without entering duplicate information into the DD Table.

Remove Dive

Function

Operation

Removes a dive from the D.D. table.

Use the arrow keys on the Diving 5 keyboard insert to select the dive to remove and press the **Remove Dive** softkey. A confirmation box prompts you to delete the selected dive. Press **enter** to delete it or press **quit** to leave the selected dive in the D.D. table.

Figure 3-AE Enter New D.D.

Edit DD

Function

Operation



Allows you to edit the D.D. for any dive.

Use the arrow keys on the Diving 5 keyboard insert or type the dive number and position to select the desired dive. Then use the arrow softkeys to select the dive height for which to edit the D.D. Press the **Edit DD** softkey, type the new D.D. and press **enter** to place the new D.D. in the database, or press **quit** to exit without changing the selected D.D.

Print DD Table

Function

Operation

Prints the internal DD Table. Having a printed DD table makes it easy for you to verify the DD for any listed dive.

Press this softkey to print the DD Table.

Alpha Export

Function

Operation

Allows you to export diving meet data from Diving 5 to a computer running diving meet management software.

After attaching the computer to your System 5 as directed in the diving meet management software manual, press this softkey to transfer data.

Display

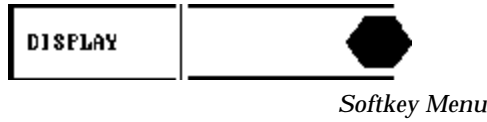

Figure 3-AF Display

Summary

The **Display** softkey allow you to display all dive information on the screen.

Operation

Press this softkey to display current dive information on the display screen. The Display softkey menu provides further display options. Those options are explained below.

DISPLAY DIVES	
DISPLAY JUDGES	
LAST DIVER	
NEXT DIVER	
LAST ROUND	
NEXT ROUND	

Colorado Time Systems Diving 5

DIVER 01	JOHN	TOTAL	55.75
DIVER 02	TERRY	TOTAL	50.30
DIVER 03	MARK	TOTAL	77.10
DIVER 04	DAVE	TOTAL	44.80
DIVER 05	PAUL	TOTAL	51.50
DIVER 06	MIKE	TOTAL	68.80

ROUND 01 103 TUCK [C] D.D. 1.6 AWARD 22.40

DISPLAY DIVERS

Figure 3-AG Display Diver Information Main Screen

Display Dives

Function

This softkey displays specific information on each dive for the currently selected diver, including the dive and position, D.D. award and total score.

MAIN MENU		DIVER		DIVES		Colorado Time Systems Diving 5	
ROUND 01	103 TUCK [C]	D.D.	1.6	AWARD	22.40		
ROUND 02	104 PIKE [B]	D.D.	2.3	AWARD	33.35		
ROUND 03		D.D.		AWARD			
ROUND 04		D.D.		AWARD			
ROUND 05		D.D.		AWARD			
ROUND 06		D.D.		AWARD			
ROUND 07		D.D.		AWARD			
ROUND 08		D.D.		AWARD			
DIVER 01 JOHN				TOTAL	55.75		
DISPLAY DIVES							

Figure 3-AH Display Dive Information Screen

Operation

Press this softkey to display specific information on each dive for the currently selected diver. To display the dive information for another diver or round, press the appropriately labeled softkey. To return to the diver display, press the **Display Divers** softkey.

Display Judges

Function

This softkey displays the scores each judge awarded the current dive.

MAIN MENU		DIVER		JUDGES		Colorado Time Systems Diving 5	
JUDGE NUMBER	1	4.0					
JUDGE NUMBER	2	4.5					
JUDGE NUMBER	3	5.5					
JUDGE NUMBER	4	---					
JUDGE NUMBER	5	---					
JUDGE NUMBER	6	---					
JUDGE NUMBER	7	---					
JUDGE NUMBER	8	---					
JUDGE NUMBER	9	---					
JUDGE NUMBER	10	---					
DIVER 01 JOHN				TOTAL	55.75		
ROUND 01	103 TUCK [C]	D.D.	1.6	AWARD	22.40		
DISPLAY JUDGES							

Figure 3-AI Display Judges Information Screen

Operation

Press this softkey to display all scores for the current dive. To display the judges' scores for another diver or round, press the appropriately labeled softkey. To return to the diver display, press the **Display Divers** softkey.

Last Diver

Function

Displays the previous diver on the list.

Operation

Press this softkey to display the desired information for the next diver on the list.

Next Diver

Function

Displays the next diver on the list.

Operation

Press this softkey to display the desired information for the next diver on the list.

Last Round

Function

Displays the previous round for the current diver.

Operation

Press this softkey to display the desired information for the previous round.

Next Round

Function

Displays the next round for the current diver.

Operation

Press this softkey to display the desired information for the next round.

Print

Summary



The **Print** softkey allows you to make additional printouts of information from the current meet or from a stored meet. You may press more than one softkey to make several printouts. The pages of information you select are printed in the order you press the softkeys. Make sure your printer is properly attached to the System 5, is **on-line**, and is loaded with paper before attempting to print. The Print softkey menu offers several printing options.







SINGLE DIVER DATA	
ATJ. DIVERS DATA	
BANK BY DIVER	
BANK BY PLACE	
ONE DIVE	
FORM FEED	

Figure 3-AJ Print Softkey Menu

Operation

Press the **Print** softkey to access the Print softkey menu. The softkeys that make up the print menu are shown in Figure 3-AJ. Printing begins as soon as you press one of these softkeys.

Single Diver Data

Function

Prints all dive information for a specific diver.

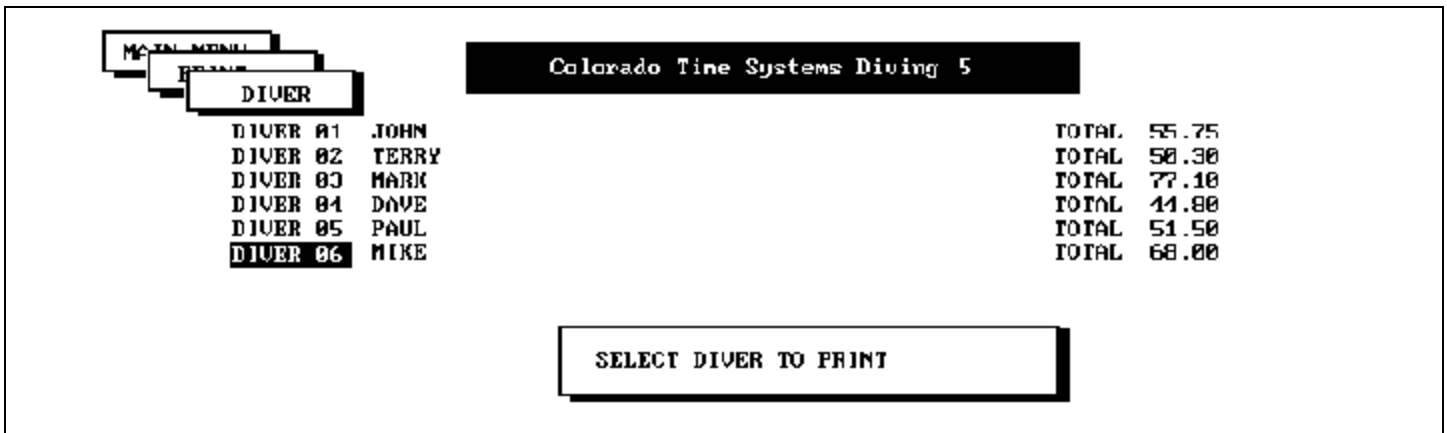

Figure 3-AK Diver Print Selection Screen

Operation

Press this softkey to display the current divers. Use the **up** or **down** arrow key to highlight the diver whose information you want to print and press **enter**. Repeat the process to print another diver's information.

All Divers' Data

Function

Prints all dive information for the current diving session.

Operation

Press this softkey to print all dive information for the current diving session.

Rank By Diver

Function

Prints all dive information for the current diving session sorted by diver.

Operation

Press this softkey to print all dive information for the current diving session sorted by diver.

Rank By Place

Function

Prints all dive information for the current diving session sorted by place.

Operation

Press this softkey to print all dive information for the current diving session sorted by place.

One Dive

Function

Prints information for a specific dive.

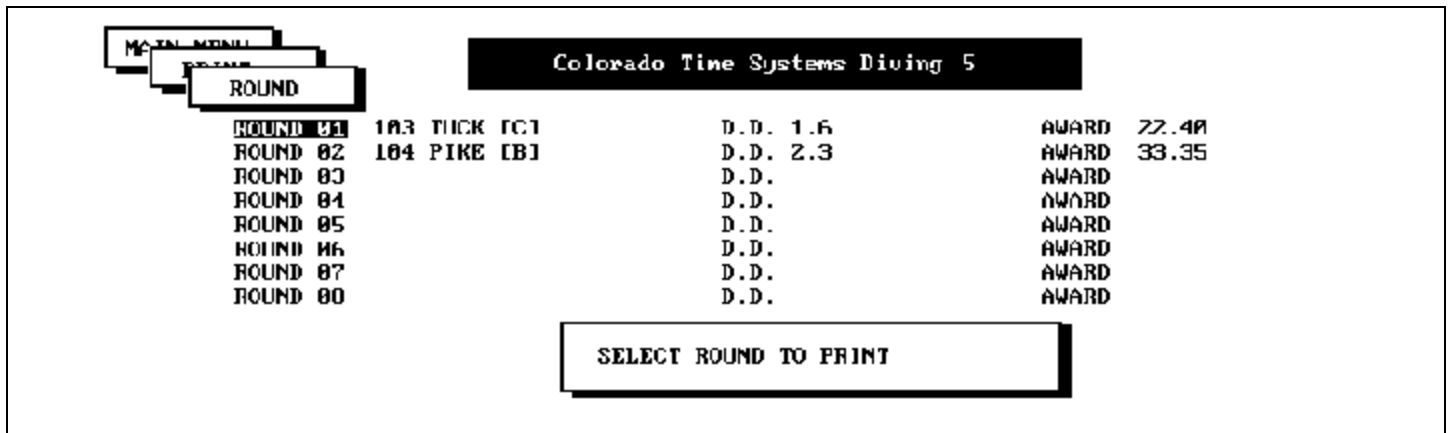

Figure 3-AL Print Dive Selection Screen

Operation

Press this softkey to display a diver selection list similar to that shown in Figure 3-AK on page 3-26. Highlight the diver whose dive(s) you want to print using the **up** or **down** arrow key and press **enter**. The next screen, Figure 3-AL, displays the full list of dives for the selected diver. Highlight the dive you want to print and press **enter** to begin printing. You may select additional dives from the list.

Form Feed

Function

Advances the paper to the top of the next page. Provides page breaks between pages of dive information.

Operation

Press this softkey at the point in the print sequence where you want to end a page. Any information printed after a form feed begins at the top of the next page.

Stored Data



Summary

The **Stored Data** softkey allows you to save the current diving event program and provides access to diving events that have already been saved. Pressing the **Stored Data** softkey displays the Stored Data display screen and softkey menu. Diving 5 uses the System 5's memory to store up to 600 divers' results. The stored diving events are numbered 1 through 32. If you use all 32 memory slots, you must delete one stored diving event before saving a new one. All diving events stored are held in memory when you turn off your System 5.







LOAD EVENT	
SAVE EVENT	
DELETE EVENT	
	
EXPORT EVENT	
IMPORT EVENT	

Figure 3-AM Stored Data Softkey Menu

X Note: Diving 5 shares memory space in your System 5 with the Pace Clock and Synchronized Swimming programs. If no memory is available to save Diving 5 sessions, you must delete one or more events saved with either Pace Clock 5 or Synchronized Swimming 5.

Load Event

Function

Allows you to load a stored diving event from memory.

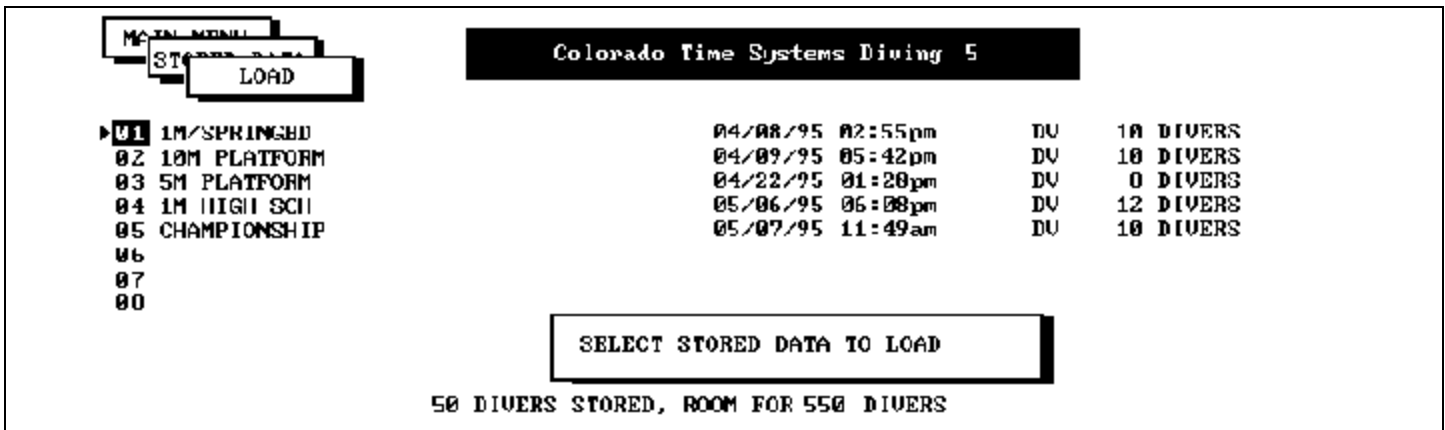

Figure 3-AN Load Event Selection Screen

Operation

Press the **Load Event** softkey and use the **up** or **down** arrow key to highlight the diving event you want to load. Diving 5 selects the most recent event by default. Press **enter** to load the selected event or press **quit** to cancel the Load Event function without loading an event.

Save Event

Function

Allows you to save a diving event for later use. This includes saving diving events that you have programmed in advance and diving events that are already completed. For a completed diving event, all scores and final results of the competition are also saved.

Operation

After programming or completing a diving event, press the **Save Event** softkey to store it in memory. The display prompts you to name the event you want to save. Type a name that will help you remember the event and press **enter**. The screen updates the amount of memory used and available. Press **quit** to return to the main screen.

Delete Event

Function

Allows you to delete a stored diving event from memory. Use this function to delete unwanted events or to make room for new events.

Operation

X Caution: Make sure the event you have selected is the one you really want to delete. Once you delete an event, it cannot be restored.

Press the **Delete Event** softkey and then use the **up** or **down** arrow key to highlight the diving event you want to delete. Diving 5 selects the oldest event by default. Press **enter** to delete the selected event. After deleting unwanted events, press **quit** to return to the main screen.

Export Event

Function

Allows you to download the currently-loaded Diving event, including all diver data, to a computer running diving meet management software.

Operation

Make sure the serial cable from your computer is connected to Com Port 1 on the System 5 I/O panel before proceeding. Load the desired Diving event using the **Load Event** softkey as explained on the previous page. Press the **Export Event** softkey to download the selected event to your computer. Refer to your diving meet management software instruction manuals for information on how to use the downloaded event.

Import Event

Function

Allows you to upload a Diving event, including all programmed diver data, from a computer running diving meet management software.

Operation

Make sure the serial cable from your computer is connected to Com Port 1 on the System 5 I/O panel before proceeding. Load the desired Diving event into your diving meet management software and prepare it for uploading as explained in your diving meet management instruction manual. Press the **Import Event** softkey to upload the selected event from your computer. The new event appears on the Stored Data screen. Use the **Load Event** softkey to load the new event.

Setups



Summary

The **Setups** softkey has two main functions. First, it provides access to features which allow you to set up your diving meet. Second, it allows you to customize your scoreboard displays.

DROP DIVER	
JUDGES USED	
SCBD. MENU	
START FOUND	
START POINTS	
# OF DIVERS	

Figure 3-AO Setups Softkey Menu

Operation

Press the **Setups** softkey to display the Setups softkey menu. The available options are described below. Press **quit** to leave Setups.

Turning Judges On/off

X Note: This is the only point in the Diving 5 program in which you can turn judges on or off after you have set up a diving program. Be sure to turn on the correct number of judges before the meet begins.

Function

Turns judges on or off, depending on current state. For example; if Judge 1 is currently off, pressing **edit judge 1** turns Judge 1 on, as indicated on the display screen. See Figure 3-AP for an example screen.

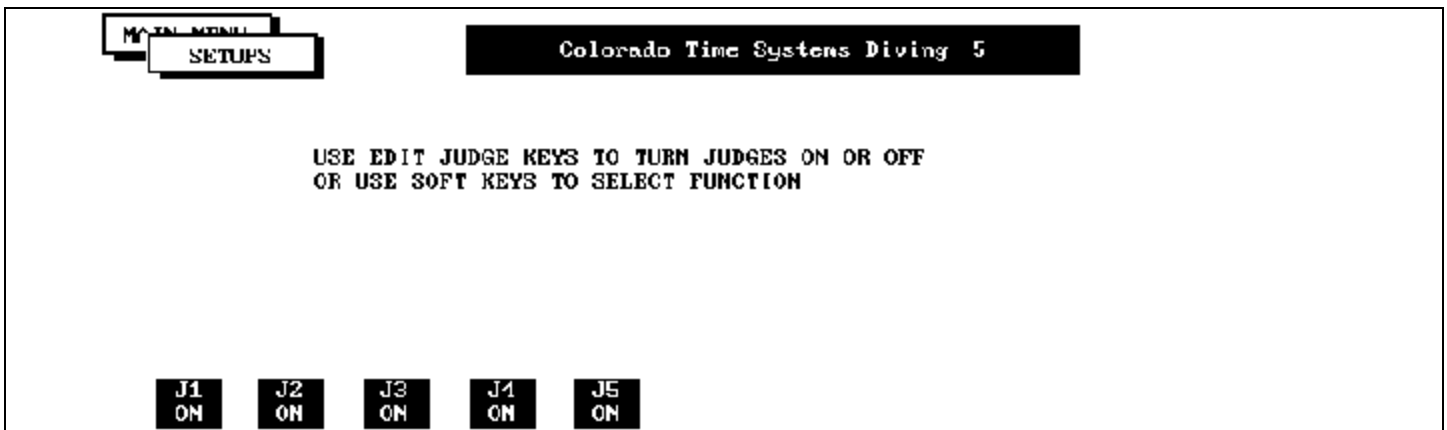

Figure 3-AP Turn Judges On/Off Screen

Operation

Press the **edit judge** key for each judge used in the current meet. Press the appropriate **edit judge** key again to turn off a selected judge. The display screen indicates which judges are currently active.

Drop Diver

Function

Drops the selected diver from the meet.

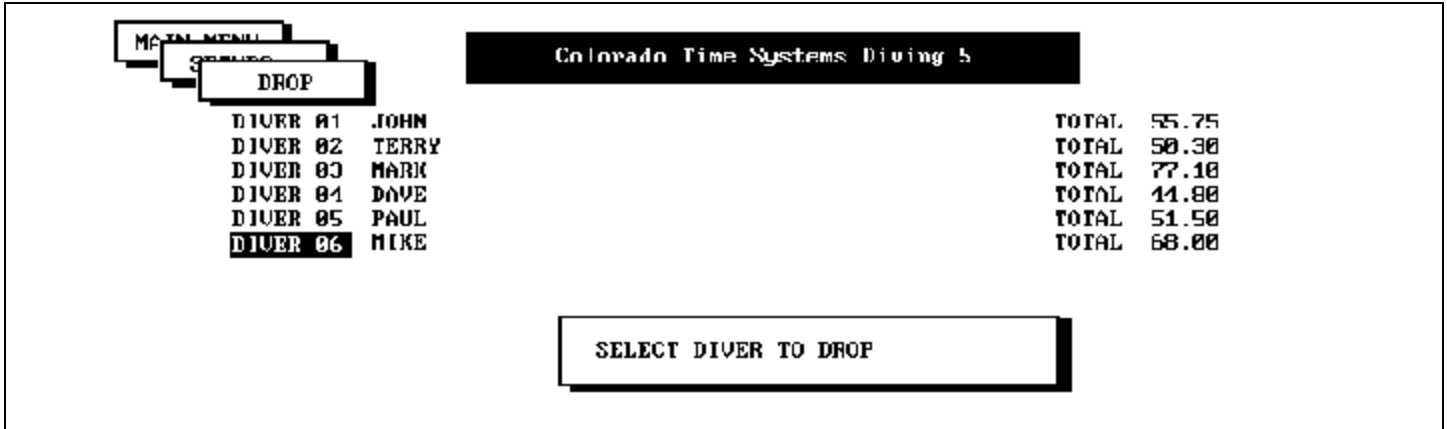

Figure 3-AQ Drop Diver Selection Screen

X Note: To return a dropped diver to the meet, highlight the dropped diver's number and press **enter**. To remove a diver permanently, use the **Delete Diver** softkey as explained on page 3-20.

Operation

Press this softkey to display a list of the divers in the current meet. Highlight the diver you want to drop using the **up** or **down** arrow key and press **enter**. The display screen indicates that the selected diver has been dropped.

Judges Used

Function

Selects the number of judges used to compute awards. The number of judges allowed is either **3** or **5**. Diving 5 automatically drops the high and low score when computing awards. If there are 5 judges, this setup option should be set to use 3 judges for award computation. If there are 7 or more judges, set this option to 5.

Figure 3-AR Select Number of Judges to Score Meet

Operation

To change the number of judges used to compute awards, press the **Change** softkey. Press **quit** when done.



Scbd Menu (Scoreboard)

Summary

Provides access to special scoreboard control and display features.

Operation

Press the **Scbd** softkey to display the Scoreboard softkey menu.

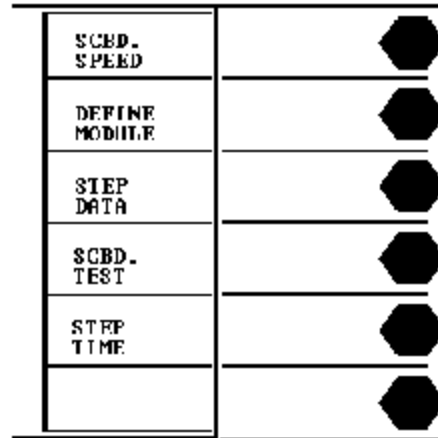

SCBD. SPEED		⬢
DEFINE MODULE		⬢
STEP DATA		⬢
SCBD. TEST		⬢
STEP TIME		⬢
		⬢

Figure 3-AS Scoreboard Setup Softkey Menu

Scbd Speed

Function

Matches the data transmission rate from Diving 5 to the communication rate of your scoreboard. Set the scoreboard speed to either high (9600 baud) or low (2400 baud) speed. See your scoreboard manual for the communication rate of your scoreboard.



Figure 3-AT Set Scoreboard Speed Window

Operation

Press the **Scbd Speed** softkey to display the current data transmission rate. Press the **Change** softkey to select either high or low speed. When the desired speed is selected, press **quit** to accept the entry and return to the previous screen.

Define Module

Function

Allows you to display or change the scoreboard module definitions. Scoreboard module diagrams appear on page 2-5.

Operation

Press the **Define Module** softkey to display your current scoreboard module definitions, shown in Figure 3-AU, and the Define Modules softkey menu, shown in Figure 3-AV. The left and middle columns on the screen indicate the scoreboard channel and the display description. The right column indicates the scoreboard module on which the information in the other two columns is displayed.

Scoreboard module definition is a complex operation which should not be attempted by an inexperienced operator. Before attempting to define scoreboard modules, carefully read the Scoreboard section in Chapter 2 of your *System 5 Swimming User Guide*. As in Swimming, all Diving 5 scoreboard module logical addresses (modules) default to the physical addresses (scoreboard channels). For example, the physical address of the scoreboard module displaying data for Judge 1 is 01, so the logical address is also 01. If you want Judge 1's (01) scoreboard module to display Judge 10's data, set Judges 1's logical address (module) to 0A.

CHANNEL	(description)	IS DISPLAYED ON MODULE
01	judge 1	01
02	judge 2	02
03	judge 3	03
04	judge 4	04
05	judge 5	05
06	judge 6	06
07	judge 7	07
08	judge 8	08
09	judge 9	09
0A	judge 10	0A
0B	dd round award	0B
0C	current diver total	0C
0D	lead diver total	0D
10	dd dive pos	10
11	round award	11
12	dd award	12
13	j1 j2 j3 j4	13
14	j5 j6 j7 j8	14
15	j9 j10 award	15
16	time of day	16
17	current diver total	17
18	lead diver total	18
19	j9 round award	19

Module 0F single line sequencing is not definable

Figure 3-AU Scoreboard Definition Screen

To change a module definition, press the **up** or **down** arrow key to highlight the desired display module and press **enter**. The display indicates that you are editing the selected module. Use the numeric keypad to enter numbers and either the alphabetic keyboard keys or softkeys to enter letters. When you have entered the desired module definition, press **enter** to accept the entry. If you change the wrong module or enter the wrong information, press **quit** instead of **enter** to clear the erroneous entry. After defining scoreboard modules, press **quit** to return to the previous screen.

The default scoreboard module definitions are shown in the following table:

Channel	Description	Displayed on Module
01	Judge 1	01
02	Judge 2	02
03	Judge 3	03
04	Judge 4	04
05	Judge 5	05
06	Judge 6	06
07	Judge 7	07
08	Judge 8	08
09	Judge 9	09
0A	Judge 10	0A
0B	DD, Round, Award	0B
0C	Current Diver Total (.01)	0C
0D	Lead Diver Total (.01)	0D
10	DD, Dive, Position	10
11	Round, Award	11
12	DD, Award	12
13	J1, J2, J3, J4	13
14	J5, J6, J7, J8	14
15	J9, J10, Award	15
16	Time of Day	16
17	Current Diver total (.001)	17
18	Lead Diver Total (.001)	18
19	J9, Round, Award	19

Single Line Scoreboard, Module 0F

If you are using a single line scoreboard, all dive information is set at the factory to display in sequence on scoreboard module 0F. You cannot change the information displayed on module 0F. For more information, refer to page 2-6.

X Note: You cannot select the sequencing order of the single line scoreboard, module 0F.

Record Setups

Function

Stores the currently displayed module definitions in permanent memory. These settings are retained when you turn off your System 5. Remember that you can re-define the scoreboard modules at any time.







RECORD SETUPS	
BLANK MODULE	
	
	
	
	

Figure 3-AV Define Modules Softkey Menu

Operation

After defining the scoreboard modules to suit your needs, press the **Record Setups** softkey to store the current definition in permanent memory. If you change module definitions without pressing the **Record Setups** softkey, **the changes only affect the current Diving 5 session and are lost when you turn off your System 5.**

Blank Module

Function

This softkey allows you to blank a scoreboard module for the entire diving session. If you record a scoreboard setup with blanked module(s), the setup including the blanked module(s) is stored in permanent memory.

Operation

Press the **up** or **down** arrow key to highlight the module you want to blank and press the **Blank Module** softkey. To unblank a module, highlight a blanked module, press **enter** to edit, type the desired module definition, and press **enter**. Press **quit** to return to the Scoreboard softkey menu.

Step Data

Function

Sequences the results of the last dive on a single-line scoreboard (module 0F) an additional time. This softkey is only active if you are using a single-line scoreboard.

Operation

Press this softkey to sequence again the results of the last dive on your single-line scoreboard.

Scbd Test

Function

Displays the numeral **8** on all available scoreboard modules. Tests each digit segment for proper operation and each module for proper connection to your System 5.

Operation

To initiate a scoreboard test, press the **Scbd Test** softkey. Check your scoreboard for proper operation. If any segments or digits do not operate properly, check all cable connections and run the test again. If your scoreboard still does not work properly, it may need service. Call Colorado Time Systems' Customer Service Department for assistance.

Step Time

Function

Press any key to end the test.

Sets the time in seconds each channel is displayed on a single-line scoreboard, up to a maximum of 9 seconds.



ENTER STEP TIME FOR MODULE OF 05

Figure 3-AW Single-Line Scoreboard Step Time

Operation

Press this softkey, type the time in seconds you want each channel to display on your single-line scoreboard using the numeric keypad, and press **enter**. The maximum time is 9 seconds.

Exiting the Scoreboard Menu

To exit the Scoreboard softkey menu and return to the Setups softkey menu, press **quit**.

Start Round

Function

Selects the round with which to begin the meet. Use this softkey to start the second day of a meet with the correct round, or to start with the correct round if you turned off your System 5 during the meet.



START AT ROUND NUMBER 05

Figure 3-AX Round to Start the Meet

Operation

Press this softkey, type the number of the desired start round using the numeric keypad, and press **enter**. If the desired start round is less than 10, type a leading zero, for example **05**.

Start Points

Function

Sets the number of points for a diver to begin the current diving session. Use this softkey to update scores from the previous day's session or any other time when you need to enter a diver's score from an earlier session.

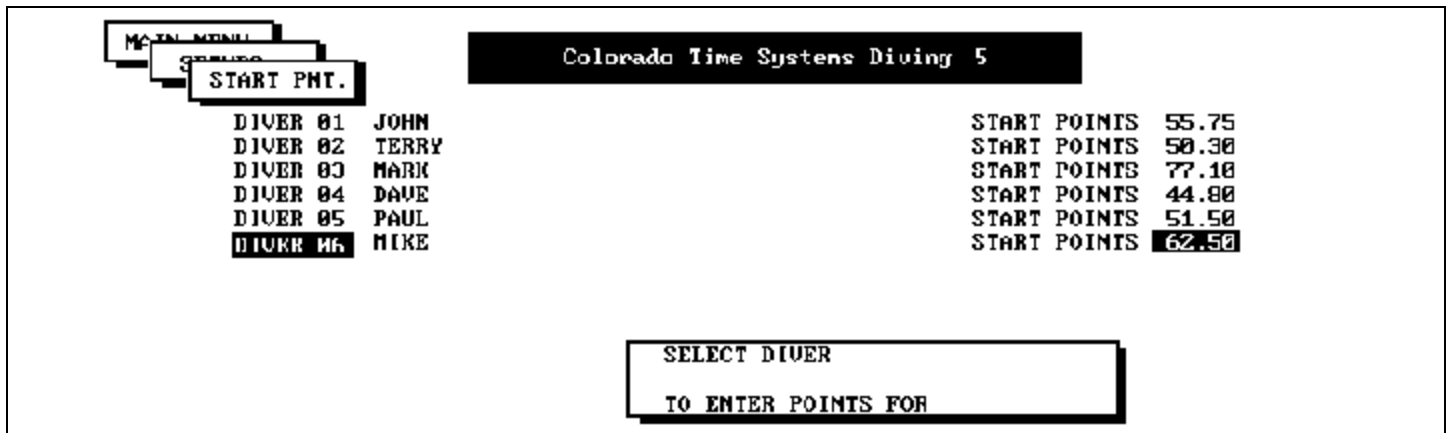

Figure 3-AY Points to Start Meet Screen

Operation

Press this softkey to display a list of divers in the current session. Highlight the diver whose score you want to update using the **up** or **down** arrow key and press **enter**. Type the diver's score using the numeric keypad and press **enter**. The decimal point is inserted automatically.

Of Divers

Function

Sets the number of divers for the current session. Use this feature to set the number of divers before beginning a diving meet in Enter Data on the Fly mode.

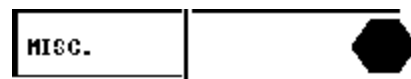

Figure 3-AZ Number of Divers in the Meet

Operation

Press this softkey, type the number of divers for the current diving session using the numeric keypad, and press **enter**.

Misc



Summary

This softkey provides access to miscellaneous functions of Diving 5.

BEEP VOLUME	
RUN SWIMMING	
SOFTWARE VERSION	
SET CLOCK	
RANK ON SCBD	
EXTERNAL MONITOR	

Figure 3-BA Misc Softkey Menu

Operation

Press the **Misc** softkey to display the Miscellaneous softkey menu. Press **quit** to return to the main screen when you have finished using miscellaneous features.

Beep Volume

Function

Allows you to set the volume of the beep that indicates a key pressed.



BEEP VOLUME IS 03

Figure 3-BB Set Beep Volume

Operation

Pressing the **Beep Volume** softkey displays a window indicating the current volume level, which is a number from 0-3. To increase the beep volume, press the **up** arrow key. To store the new beep volume, press the **Record** softkey.

Run Swimming

Function

Returns your System 5 to Swimming 5.

Operation

Press this softkey to return to Swimming 5. No other action is necessary.

Software Version

Function

Displays the version of Diving 5 software you are using.

Set Clock

Function

Allows you to set you System 5 internal clock.

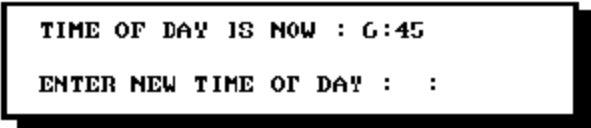

TIME OF DAY IS NOW : 6:45
ENTER NEW TIME OF DAY : :

Figure 3-BC Enter Time of Day

Operation

Press the **Set Clock** softkey to display the current time from your System 5 internal clock. Use the numeric keypad to enter the correct time and press **enter**. To exit without changing the time, press **quit** instead of **enter**.

Rank On Scbd

Function

Displays the top ten divers, ranked by total points, on the scoreboard.

Operation

Press the **Rank on Scbd** softkey to display the top ten divers on your scoreboard.

External Monitor

Function

Sends meet information to a television monitor or separate computer for divers and others to observe. The information displayed includes the rankings of the top ten divers, the results of the last dive, and the points required to overtake the leader.

The television monitor or computer you are using must be connected to the Computer Port 2 connector on the back panel of your System 5.

X Caution: Setting up this option requires knowledge of the control code(s) used by the television or computer monitor you are using to clear its screen and to move the cursor to the home position. In the example shown in Figure 3-BD, the control code for both of these functions is 0C. Be sure you have the manual for the television monitor or computer handy before attempting to use this option.

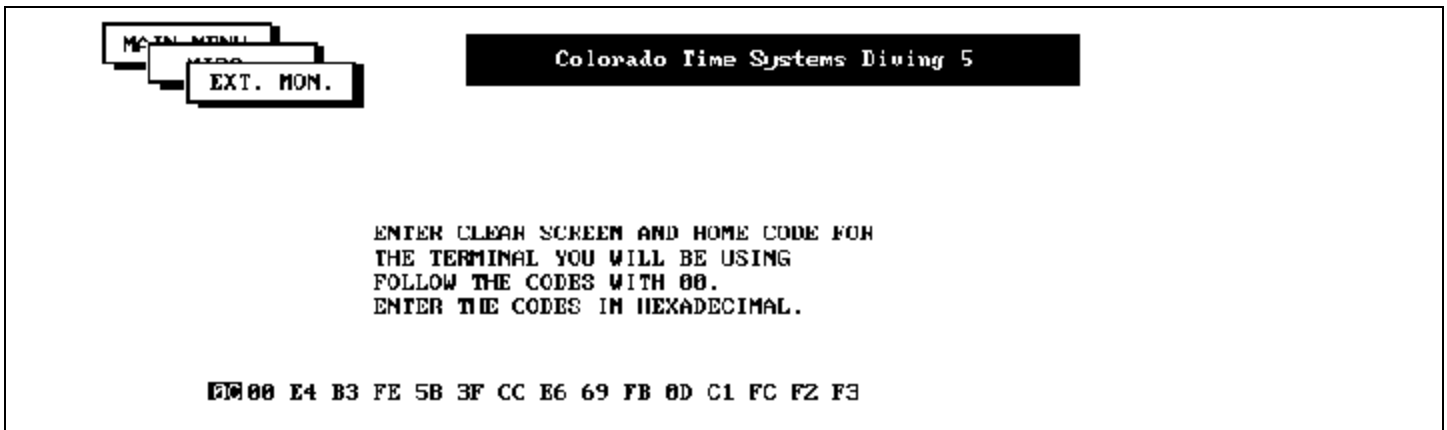

Figure 3-BD Set External Monitor Parameters

Operation

Press the **External Monitor** softkey to set up this option. Use the numeric keypad and alphabetic keys to enter the Clear Screen/Home code in hexadecimal for your monitor. Press the bottom softkey to move to the next number as necessary to complete the Clear Screen/Home code sequence. When finished entering the control code(s), type "00." In the example shown above, "0C" is the Clear Screen/Home code. Press the **Record** softkey when you have finished entering the sequence to save it.

Index

A

Automatic Score Checking 3-3

B

Backup Button 2-2

Batteries 3-8

Beep Volume 3-38

Blank Module Softkey 3-35

C

Console Keys 3-7 - 3-8

 Battery Check 3-8

 Enter 3-7

 Help 3-8

 Quit 3-7 - 3-8

Customer Service Dept 1-1, 3-1, 3-35

D

Define Modules Softkey

 Blank Module 3-35

 Blank Modules 3-35

 Record Setups 3-34 - 3-35

Display Softkey

 Display Dives 3-23 - 3-24

 Display Judges 3-24

 Last Diver 3-24

 Last Round 3-25

 Next Diver 3-25

 Next Round 3-25

Dive Edit Softkey 3-14 - 3-15

 Change Dive/DD 3-15

 Hold/Send 3-15

 Re-Dive Last 3-15

E

Edit DD Table Softkey

 Add Dive 3-21 - 3-22

 Default DD Table 3-21

 Edit DD 3-22

 Remove Dive 3-22

Enter Data on the Fly Mode 2-6, 2-12 - 2-13, 3-13 - 3-14

Enter/Edit Softkey

 Alpha Export 3-22

 Edit DD Table 3-20 - 3-22

 Edit Dives 3-18 - 3-19

 Enter Dives 3-16

 Move Divers 3-19 - 3-20

 Print DD Table 3-22

External Monitor 3-39

I

I/O Panel 2-1 - 2-2

J

Judges I/O Connector 2-1 - 2-2

Judges: Number Used 3-31

Judges: On/Off 3-30

Judging Softkeys 3-14 - 3-15

 Change Dive/DD 3-15

 Hold/Send 3-15

 Re-Dive Last 3-15

Judging Terminals 2-1 - 2-2

K

Keyboard Insert 1-2, 2-2, 3-3 - 3-6, 3-21

 2 Point Deduct 3-4

 Alphabetic Keys 3-4

 Down Arrow 3-6

 Edit Judge 3-4, 3-30 - 3-31

 Failed Dive 3-4

 Next Dive 2-10, 2-13, 3-5 - 3-6, 3-14 - 3-15

 Position Keys 3-6

 Reflash 3-5, 3-14

 Scores 2-13, 3-4

 Space 3-5

 Up Arrow 3-6

L

LCD Screen 3-2 - 3-3

Loading Diving 5 2-2 - 2-4, 2-6, 3-1 - 3-2

M

Misc Softkey

 Beep Volume 3-38

 External Monitor 3-39

 Rank on Scbd 3-38

 Run Swimming 3-38

 Set Clock 3-38

 Software Version 3-38

Move Divers Softkey

 Delete Diver 3-20

 Insert Diver 3-20

 Move Diver 3-19 - 3-20

 Random Order 3-20

N

Numeric Keypad 3-6 - 3-7

 C/E (Clear Entry) 3-7

 Enter 3-7

O

Options Softkey Menu 2-7

Options Softkeys 2-7, 3-9

 Enter Data On the Fly 3-13 - 3-14

 Program New Data 2-7 - 2-9, 3-10 - 3-13

Index

- Retrieve Stored Data 2-9, 3-9 - 3-10
- Return to Swimming 3-14
- P**
- Position Keys 3-6
- Print DD Table 3-22
- Print Softkey
 - All Divers' Data 3-26
 - Diver Data 3-25 - 3-26
 - Form Feed 3-27
 - One Dive 3-26 - 3-27
 - Rank by Diver 3-26
 - Rank By Place 3-26
 - Single Diver Data 3-25 - 3-26
- Program Mode 2-7 - 2-12, 3-10 - 3-13
- R**
- Running Diving 2-2 - 2-4, 2-7, 3-2
- Running Swimming 3-38
- S**
- Scbd Softkey
 - Blank Module 3-35
 - Define Module 3-32 - 3-34
 - Exiting 3-36
 - Scbd Speed 3-32
 - Scbd Test 3-35
 - Step Data 3-35
 - Step Time 3-36
- Score Checking 3-3
- Scoreboard
 - Cabling 2-2
 - Setup 2-4 - 2-6, 3-32 - 3-34
 - Single-Line 2-6, 3-34 - 3-36
- Search DD Table 3-21
- Self Test 3-1
- Setups Softkey
 - # of Divers 3-37
 - Drop Diver 3-31
 - Judges On/Off 3-30 - 3-31
 - Judges Used 3-31
 - Scbd Menu 3-32 - 3-36
 - Start Points 3-36 - 3-37
 - Start Round 3-36
- Softkeys
 - # of Divers 3-37
 - Add Dive 3-21 - 3-22
 - Alpha Export 3-22
 - Beep Volume 3-38
 - Blank Module 3-35
 - Default DD Table 3-21
 - Define Module 3-32 - 3-34
 - Delete Diver 3-20
 - Delete Event 3-29
 - Display 3-23 - 3-25
 - Display Dives 3-23 - 3-24
 - Display Judges 3-24
 - Drop Diver 3-31
 - Edit DD Table 3-20 - 3-22
 - Edit Dives 3-18 - 3-19
 - Enter Data on the Fly 3-13 - 3-14
 - Enter/Edit 3-15 - 3-20
 - Export Event 3-29
 - External Monitor 3-39
 - Import Event 3-29
 - Insert Diver 3-20
 - Judges Used 3-31
 - Judging Softkeys 3-14 - 3-15
 - Load Event 3-28
 - Main Softkey Menu 3-8
 - Misc 3-37 - 3-39
 - Move Divers 3-19 - 3-20
 - Options Menu 2-2, 3-9 - 3-14
 - Print 3-25 - 3-27
 - Print DD Table 3-22
 - Program New Data 2-7 - 2-8
 - Random Order 3-10 - 3-13
 - Rank on Scbd 3-38
 - Remove Dive 3-22
 - Retrieve Stored Data 3-9 - 3-10
 - Return to Swimming 3-14
 - Run Swimming 3-38
 - Save Event 3-28 - 3-29
 - Scbd 3-33
 - Scbd Menu 3-32 - 3-36
 - Scbd Speed 3-32
 - Set Clock 3-38
 - Setups 3-30 - 3-37
 - Software Version 3-38
 - Start Points 3-36 - 3-37
 - Start Round 3-36
 - Step Data 3-35
 - Stored Data 2-9, 2-12, 3-18, 3-27 - 3-29
- Sports Menu 2-3, 3-1
- Stored Data Softkey
 - Delete Event 3-29
 - Export Event 3-29
 - Import Event 3-29
 - Load Event 3-28
 - Retrieve Stored Data 3-13
 - Save Event 2-9, 2-12, 3-28 - 3-29
- T**
- Test/Programming Menu 3-1
- Touchpad 2-2